

DESIGN AND ANALYSIS WATER PURIFICATION SYSTEM FILTER CARTRIDGE

Submitted By

Nafiz Iqbal	BME 1903019483
Tuhin Shaik	BME 1903019473
Saiful Islam	BME 1903019478
Mokhlesur Rahman	BME 1903019484
Moshiur Rahman	BME1903019474

Supervisor:

Md Ahatashamul Haque Khan Shuvo
Lecturer
Department of Mechanical Engineering
Sonargaon University (SU)



**DEPARTMENT OF MECHANICAL ENGINEERING
SONARGAON UNIVERSITY(SU)**

May 2022

ACKNOWLEDGMENTS

First, I thank the Almighty God for this exceptional experience as a student at the sonargaon university in mechanical engineering, Dhaka bangladesh. I wish to thank several individuals who have continuously supported me throughout this entire adventure. I would like to express my gratitude to Md Ahatashamul Haque khan shuvo Lecturer and Coordinator of Sonargaon University for his review of this thesis readability from a engineer perspective.

With utmost appreciation, I would like to thank my thesis advisors. for their guidance, support, and encouragement throughout this process. I sincerely thank Our Coordinator for not only his support as second reader but also for his guidance throughout this whole process.

I would specifically thank my team member, nafiz Iqbal, Thuhin Shaikh, for their support, patience, and prayers throughout this work and my studies at Sonargaon University. I must admit that without them, this task would not have happened. I also wish to thank Sonargaon university library for their huge book collection.

Abstract

The study attempts to investigate the effect of tap water in Dhaka city. Purification system removal of arsenic, bacteria, virus, metal, dust another particle by Filter cartridge. In addition, the study focused on the determination of general flow curve for the filter, determination of time required for volume of water to be filtered and also to comprehend the social acceptance of the filter. Five filters from Dhaka City were selected for the research. Altogether 25 water samples were collected and flow rate of each sample was taken. The collected samples were tested for arsenic, bacteria, virus, metal, dust another particle, the social acceptance of the filter was evaluated through questionnaire and informal survey. To accomplish the objective some hypothesis was set. And the result obtained from the research was compared with the hypothesis set. And according to the comparison the result and conclusion were made. Potable water is critically important in the battlefield. U.S. soldiers and coalition forces suffered from water-borne diseases such as skin abscesses, cellulitis, skin infections, and diarrhea due to improperly treated water.

Contents

ACKNOWLEDGMENTS	i
Abstract	ii
CHAPTER-1	1
1.1 INTRODUCTION.....	1
1.2 BACKGROUND.....	1
1. 4 PROBLEM STATEMENT AND RESEARCH QUESTION.....	2
1.5 OBJECTIVES	3
1.6 BENEFIT OF THE STUDY	3
Benefit to U.S. Military	3
Benefit to Local Population.....	4
1.7 SCOPE, LIMITATIONS AND ASSUMPTIONS.....	4
1.8 METHODOLOGY AND APPROACH	5
1.9 ORGANIZATION OF THE STUDY.....	6
CHAPTER - 2	7
REVIEW OF RELEVANT LITERATURE.....	7
2.1 PRIMARY WATER SOURCES IN WEST AFRICA	7
Borehole Water System (BWS).....	7
2.1.1 Rain Water.....	7
2.2 REVIEW OF WATER PURIFICATION AND TREATMENT TECHNOLOGIES	8
2.3 REVIEW OF WATER QUALITY IN WEST AFRICA	13
CHAPTER -3	16
OPERATIONAL ANALYSIS AND USER NEEDS	16
3.1 NEEDS ANALYSIS.....	16
3.2 OPERATIONAL REQUIREMENTS.....	17
1. High-Level User Requirement.....	17
2. System Size.....	17
3. Operational Concept.....	17
4. Proposed Maintenance Concept	18
5. Environmental Factor	18
6. System Reliability.....	18
3.3 FUNCTIONAL ANALYSIS	19
1. Functional Hierarchy	19
3.4 Functional Flow Block Diagram.....	22
3.5 Timeline Analysis.....	24

3.6 LIST OF SYSTEM REQUIREMENTS	25
3.7 TECHNOLOGY FEASIBILITY	25
Modified Reverse Osmosis System (MROS)	26
Contracted Water Supplier (CWS)	26
3.8 COST ANALYSIS OF THE WATER PURIFICATION SYSTEM	28
CHAPTER-4	35
DETAIL DESIGN OF SYSTEM COMPONENTS	35
4.1 SYSTEM DESCRIPTION.....	35
Power System	36
Monitor/Detector System.....	36
Pump Systems.....	37
Pre-Filter Subsystem.....	38
Membrane Subsystem.....	38
Post-Filter Subsystem	40
Tank Subsystem.....	40
Disinfection System.....	41
4.2 WATER SAMPLING ANALYSIS	41
4.3 WATER PURIFICATION SYSTEM PHYSICAL MODEL	42
Model Development and Implementation	43
1. Operational Test and Evaluation	44
2. Pre-Water Treatment Test Analysis.....	45
OT&E Procedure	47
4.4 SYSTEM RELIABILITY ANALYSIS	49
System Overall Reliability Model	49
Fault-Tree Analysis	54
4.5 INTEROPERABILITY REQUIREMENTS.....	55
CHAPTER-5.....	56
5.1 OPERATIONAL USE AND SYSTEM SUPPORT.....	56
CHAPTER-6	57
CONCLUSION.....	57
LIST OF REFERENCES.....	58

LIST OF FIGURES

Figure 1. RO Water Purifier Cartridge	2
Figure 2. Current Borehole Water System. Source: TWP (2020)	3
Figure 3. The “V” Model of Systems Engineering. Adapted from Conahan (2012)	6
Figure 4. Chemical and Physical Water Treatment Process and Example Technologies. Source: WIPO (2012)	9
Figure 5. Local Water Treatment Using Chlorine Tablet. Source: WHO (2013a)	11
Figure 6. Chlorination Treatment. Source: Food and Agricultural Organization of the United Nations (FAO) (1999)	11
Figure 7. Ozone Water Treatment System. Source: Food and Agricultural Organization of the United Nations (1999)	12
Figure 8. Schematic of the UV Water Treatment System. Source: World Intellectual Property Organization (2012)	13
Figure 9. Simplified Needs and Opportunities Analysis Diagram. Adapted from Conahan (2012)	16
Figure 10. Functional Hierarchy of the Water System (SV-4)	20
Figure 11. Water System FFBD	23
Figure 12. Time Line Analysis for the Water Purification Operation	24
Figure 13. A Depiction of size and dimension of MROS	26
Figure 14. System Interface Diagram (SV-1)	35
Figure 15. Physical Decomposition Level One for the Water Purification System	36
Figure 16. Physical Decomposition Level Two for the Power System	36
Figure 17. Physical Decomposition Level Two for the Monitor/Detector System	37
Figure 18. Physical Decomposition Level Two for the Pump System	38

Figure 19 Physical Decomposition Level Two for the Pre-Filter Assembly	38
Figure 20 Physical Decomposition Level Two for the Membrane Subsystem	39
Figure 21 Physical Decomposition Level Two for the Post Filter Subsystem	40
Figure 22 Physical Decomposition Level Two for the Storage Tanks System	41
Figure 23 Water Sampling Logic Diagram	42
Figure 24 Block Diagram of Water Purification Mode Prototype Model	43
Figure 25 Four Stage Prototype Model Integration	44
Figure 26 The Water Purification System Prototype Model Configuration	48
Figure 27. Water System Reliability Model ⁵⁴	50
Figure 28 RBD of Non-potable tank, Rain water tank, Power, Pump, and Monitor Systems ⁵⁵	51
Figure 29 RBD of the Pre-filters	51
Figure 30 RBD of Membrane Elements	53
Figure 31 RBD of the Post-Filters	53
Figure 32 Fault Tree Analysis of the Water System	55

LIST OF TABLES

Table 1. Physical Methods for Water Treatment at the Household level. Adapted from Sobsey (2002)	10
Table 2 Alternative Data	27
Table 3 System Selection Using Pugh Matrix	28
Table 4 Cost Breakdown of MROS	29
Table 5 Cost Analysis Summary of the MROS	31
Table 6 Cost-Breakdown of WDS	32
Table 7 Cost Analysis Summary of the WDS	32
Table 8 Cost-Breakdown of the CWS	33
Table 9 Cost Analysis Summary of the CWS	34
Table 10 Prototype Water Purification System Parts List	35
Table 11 OT&E Validation Checklist. (2020)	45

CHAPTER-1

1.1 INTRODUCTION

This chapter provides the background information on potable water and some relevant effects of contaminated water on humans. The chapter discusses the challenges supply and distribution of potable water posed to the United States forces during Operations Iraqi Freedom and Enduring Freedom. Given the current threats in the West African region, this chapter discusses the reasons there is need for a high quality water system for U.S. forces that will operate in West Africa in the future.[01]

1.2 BACKGROUND

Potable water is critically important in the battlefield. During Operation Iraqi Freedom for example, United States troops suffered from water-borne diseases due to improperly treated water. Soldiers who were deployed to Iraq experienced different kinds of skin diseases such as cellulitis, skin infections and abscesses, and diarrhea after using discolored water (Margasak 2008). There were instances when the quality of water that was provided to the troops by contractors did not meet the field water sanitary standards as specified in the Department of Army, Technical Bulletin (Medical) 577 (Granetto 2008). Additionally, the water used for laundry and personal hygiene did not meet safety standards under military regulations. As a result, the soldiers were in danger of harmful exposure to diseases through bodily cuts, wounds, eyes, nose, and mouth (Margasak 2008; Moore 2011).[02]

The water problems encountered by the U.S. troops during Operations Enduring Freedom and Iraqi Freedom triggered research at the University of North Carolina. According to University of North Carolina (UNC) Global website (Gillings School of Global Public Health 2015), “bad water can slow down and compromise a mission, hitting every man in the field. This becomes especially dangerous for troops in the Special Operation Forces (SOF) who are often operating behind enemy lines on missions where they have to be extremely mobile, quick and discreet.” The Gillings article explains that in a situation where small teams of troops are on a mission, troops rely on either bottled water or other water bodies that may be purified along their way in the area.

1.3 Water filter cartridge analysis by area basis...



Figure 1. RO Water Purifier Cartridge

1.4 PROBLEM STATEMENT AND RESEARCH QUESTION

The current BWS system in West Africa lacks capability of monitoring chemical compound, filtration, and disinfection of potable water. As a result, there is not enough potable water in West Africa to support a large-scale U.S. forces operation. This thesis addresses the following research questions:[06]

- (1) What modifications need to be made to the existing West African borehole water system (BWS) to make potable water?
- (2) What water purification system can be incorporated with BWS to provide cost-effective and safe water to U.S. forces operating in West Africa?
- (3) Would the water purification system be operationally feasible, technically feasible, and cost-effective for U.S. forces operating in West Africa?

1.5 OBJECTIVES

This research focuses on the analysis of BWS in West Africa and its ability to deliver potable water to meet the standard of U.S. forces operating in the area. Additional analysis and design will be conducted to determine if an off-the-shelf purification system could be incorporated to the existing water system. The intent of this research is to design and test a feasible and cost effective prototype of a purification system to the BWS that

will improve its capability for the local population as well as U.S. forces, if they ever operate there in the future. Figure 2 shows the current borehole water system attached with a hand pump. The system utilizes natural aquifer filtration and does not have any purification system.[07]

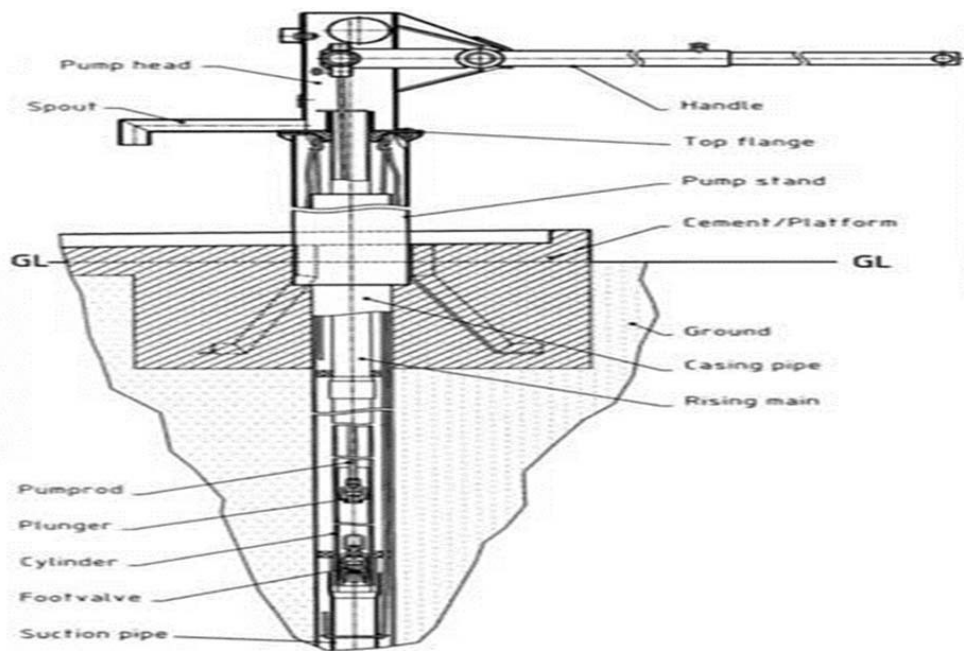

Figure 2. Current Borehole Water System. Source: TWP (2016).

1.6 BENEFIT OF THE STUDY

There are benefits for both future U.S. military operations in West Africa as well as the local population.

Benefit to U.S. Military

The benefits of the study have potential to reduce costs over baseline systems in use now, improve safer drinking water, eliminate IED attacks during water transportation process, and reduce cost savings in recycling used water bottles.[08]

- Adequate water sources in West Africa will be cost effective and reduces the use

of bottled water while in theater. As mentioned earlier, the cost of bottled water once transported can reach as high as \$4.69 per gallon.

Additionally, there is no central recycling facility in West Africa. The water system would be beneficial to U.S. forces by reducing the acquisition and transportation of bottled water and eliminate the need of central recycling facilities to recycle used bottles in West Africa. Troops' dependency on bottled water during extended military operations may interfere with the ability to apply operational design elements and could limit options in all phases of any military campaign. (Moore 2010)

- The water system is more likely to be instituted at every operating base due to its cost benefit in West African Area of Operation. The use of the system would eliminate or reduce vulnerability of Improvised Explosive Device (IED) attacks to convoys during the water transportation process. The system has performance characteristics, which makes it low cost, low maintenance, affordable, and will not require continuous electricity to operate. The water system can be implemented or sold to other third world countries that may have similar water issues as in West Africa.[09]

Benefit to Local Population

The water system will reduce communicable diseases, improve industrial needs, and provide safe water to the local population.

- A quality water system in West African region will reduce the risk of various waterborne diseases that have posed threat to the region. The system will improve the quality of drinking water in West African region and reduce the risk of consuming contaminated water.
- Industries that utilize water on a daily basis often frowns to invest in a region where potable water is not adequate. The water system would be beneficial to investors in the pursuit of business opportunities in the area.
- The system will provide the local populations of West Africa with safer water and eliminate the need for river water. With the availability of purified water in the area, those who depend on rainwater will no longer trek long distances to obtain water in the river during dry season.

1.7 SCOPE, LIMITATIONS AND ASSUMPTIONS

The research scope is to analyze and design a purification system for the existing BWS that have capabilities to monitor/detect, filter, and disinfect potable water. The research encompasses the preliminary, conceptual and detailed design of the system and does not involve the developmental stage of the system.[10]

The water regulations and laws that currently govern each West African country are in effect and would be adhered to. A new method of drilling borehole water system is not introduced and the procedures followed by the drillers are not changed. The current state of the water systems in West Africa will not affect the research.

The following is a list of assumptions that were made for the analysis and modification of the current water system:

- The borehole water and well system drilling procedures and flushing mechanisms will not change.
- The current borehole water system (BWS) construction and installed equipment to enable its operability will not change.
- The quality of borehole water will be maintained in accordance with field water sanitary standards as specified in Department of Army, Technical Bulletin (Medical) 577, “Sanitary Control and Surveillance of Field Water Supplies.”
- Chemical compounds in the soil may flow into the groundwater causing heavy metal contamination.

West Africa is a tropical rain forest region. Therefore, nitrates in the soil could leach and enter in the ground water due to heavy rainfall.

1.8 METHODOLOGY AND APPROACH

This study uses a designed-based and analytic research method with emphasis on basic systems engineering processes to include descriptive models of the problem and system. The water system design is an iterative process as illustrated in the “V” model depicted in Figure 3, in which each aspect of the design affects all others. The following systems engineering process as described by Blanchard and Fabrycky (2011) was used during this study:[11]

Identify and translate the problem into a definition of need for a system that will provide the capabilities to purify borehole water.

- Identify operational analysis using architecting in response to the identify and document user need.
- Develop system operational requirements, functional analysis and allocate system functions to components
- Conduct feasibility studies leading to the definition of purification system technology for system design.
- Accomplish the system-level verification of components and subsystems
- Perform test and evaluation of prototype model and estimate system reliability.

- Develop maintenance concept for the sustaining support of the system throughout its planned life cycle.

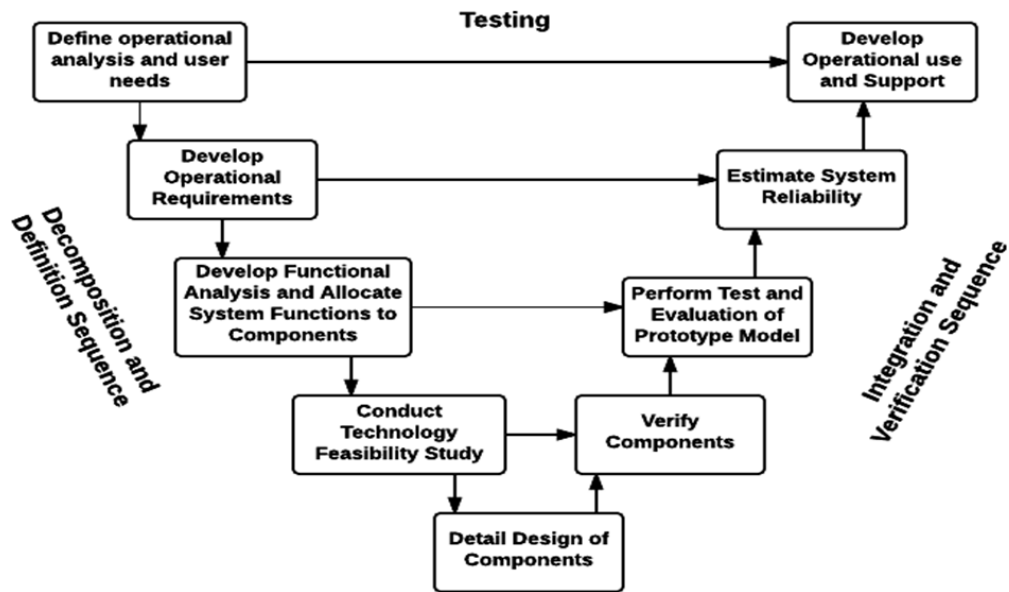

Figure 3. The “V” Model of Systems Engineering.
Adapted from Coolahan (2012).

The Pugh Matrix was used in the feasibility study to determine the water purification system to be selected for the BWS in West Africa. A cost analysis of different water purification alternatives proposed for the modified system was modeled and the preferred system based on cost and benefit was selected. A prototype model built by the use of commercial of-the-shelf components was tested and evaluated to determine the feasibility of the design. The test results were evaluated to ensure proper compatibility and integration with other external components of the system. The prototype was validated to provide assurance that it performed effectively and efficiently in accordance with the requirements.[12]

1.9 ORGANIZATION OF THE STUDY

This thesis consists of five chapters. Chapter II discusses the review of water sources in West Africa, water system technologies and review of water quality in West Africa. Additionally, this chapter presents scholarly tests, evaluation, and analysis of the BWS to enhance proper purification and treatment for human consumption. Chapter III presents the operational analysis and user needs, and discusses the needs analysis, operational requirements, operational analysis, functional analysis, system technical requirements specifications, proposed maintenance concept, operational and technical feasibility study, and economic analysis. The chapter also includes the functional hierarchy, description of functions, functional flow block diagram, and timeline analysis. Chapter IV discusses the detail design of the components, system description and physical architecture, water system operational

CHAPTER - 2

REVIEW OF RELEVANT LITERATURE

The literature review has three sections. The first is a review of primary water sources in West Africa. The second section is an overview of the water system purification and treatment technologies and their importance to this study. The third section is a review of water quality study in West Africa.[14]

2.1 PRIMARY WATER SOURCES IN WEST AFRICA

This section discusses the three primary sources of water in West Africa and their advantages and disadvantages in this research.

Borehole Water System (BWS)

Ground water is the water found under the surface of the earth and is the primary source of springs, wells, and borehole water. Borehole water is never completely pure. Its quality varies depending on the geological conditions of the soil through which the ground water flows (Ukpong and Okon 2013). A borehole is a hydraulic structure that enables the withdrawal of water from an aquifer. The current BWS in West Africa utilizes natural aquifer filtration. It is not incorporated with filtration, monitoring, and disinfection systems. In Nigeria for example, during borehole construction, the initial dirty ground water is continuously flushed until the pure and clear water is obtained. However, the application of weedicides, pesticides, and liquid waste introduce chemical compounds into the ground. Nitrates in the soil that leached and entered into the groundwater due to heavy rainfall is the primary disadvantage of borehole water system. This water condition should be remediated before the water is used.[15]

2.1.1 Rain Water

Africans obtain rainwater, the purest water source, through roof-based rainwater harvesting. West Africans use underground water tanks as a means of harvesting rainwater. One may use rain gutters attached to the roof, which are routed to the underground tank and drums to collect the rainwater. There are risks that the rainwater may be contaminated when stored in the underground or storage tanks if not treated.[16]In West Africa, dry season months are from November through April as illustrated in Figure 4. During these months, there is limited rainfall and irrigation is the only way farmers supply water to their crops. The dry season in Nigeria shows an average rainfall of 1.63mm per year with a range of 1.19 to 2.27mm per year (Balogun

et al. 2020). The rainy season occurs from May to October each year and records a mean of 1.37mm per year with a range of 0.20 to 2.28mm per year (Balogun et al. 2020). Household water harvesting is able “to meet 27.51 to 54.91% of non-potable household water demand as well as 78.34 to 156.38% of household potable water demand for a six- member household” (Balogun et al. 2016, 19). Due to dry season between the month of October and May, rainwater source is limited and scarce during this period. This is the main disadvantage of water users who depend on rainwater.[17]

2.1.2 River Water

While people obtain pure and clear borehole water and rainwater from their sources, river water lacks purity and often contains debris. Surface water is not safe for drinking unless bacteria, viruses, parasites, and protozoa are removed from it. Purification of river water is not cost effective as it may require constant replacement of the filter elements. Purification of surface water will also consume energy during the purification process. Surface water is often polluted with industrial waste and substances such as insecticides, pesticides, fertilizer, and soil erosion. Heavy metals such as acid rain, salt, silt, and mercury may enter water bodies through rain erosion. Because of these disadvantages, river water is not cost effective to purify for human consumption in West Africa.[18]

United Nations Children’s Emergency Fund (UNICEF) (2013) reported that over 2,000 children under the age of five die every day from diarrheal diseases. It is estimated that of these, over 1,800 deaths are due to bad water, improper sanitation and hygiene. The literature survey revealed that surface water in West Africa is contaminated and is the main source typhoid, cholera, dysentery and hepatitis. Lack of water treatment causes the growth of microorganisms in the water distribution system (WHO 2014). A modified water system with treatment subsystem to improve the quality of drinking water.

2.2 REVIEW OF WATER PURIFICATION AND TREATMENT TECHNOLOGIES

Water treatment is the process of making water quality acceptable for drinking, industrial use, irrigation, river flow maintenance and other uses. Global inventions in the area of water treatment promise reduced investment and operational costs for improved water systems (WIPO 2012). According to WIPO (2012, 8), “Patent-based analyses can identify the emerging technologies, players and value chains associated with next generation water treatment technologies which, if deployed at mass scale, can rapidly improve experience globally, lead to further innovation and take the technologies down the cost curve.”

Figure 4 shows water treatment technologies for physical and chemical water treatment processes indicating the vast number of technologies that are currently being used all over the world. The WHO (2011) report evaluated candidate technologies for treatment of house water supply such as improvement of microbial quality and reduction of waterborne disease.

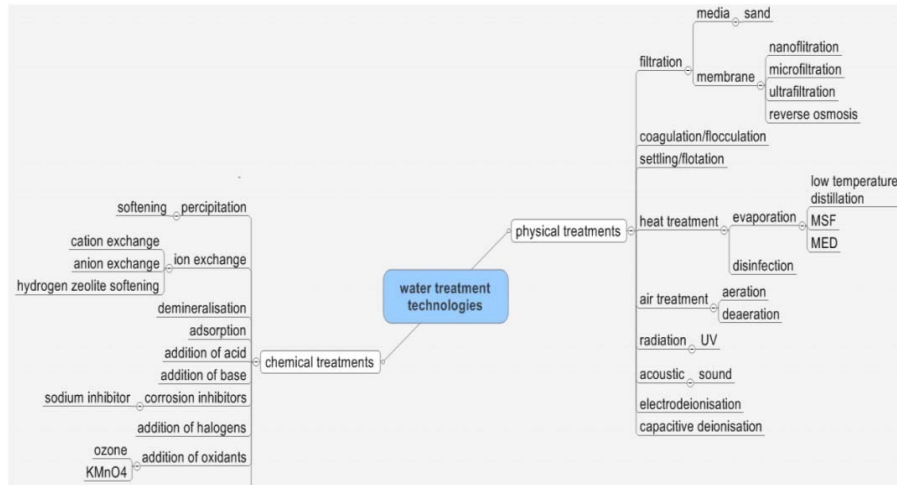

Figure 4. Chemical and Physical Water Treatment Process and Example Technologies. Source: WIPO (2012).

Water treatment technologies are divided into physical and chemical treatment methods. Physical water treatment methods are boiling, heating (fuel and solar), settling, filtering, and ultraviolet (UV) radiation. Water chemical treatment methods are comprised of Coagulation-Flocculation and precipitation, adsorption, ion exchange and chemical disinfection (WHO 2011). Tables 1 and 2 present the different water treatment methods including their availability and practicality, technical difficulty, cost, and microbial efficacy. Currently, people who live in the rural areas of West Africa utilize a combination of alternative filtration and chemical treatment methods to treat water prior to consumption. Such methods are the use of locally produced alum or Potassium

Aluminum Sulfate (Potassium alum). Alum is added to the water in order to allow the sediments to settle at the bottom of the water container. The water is then filtered through cloth and boiled prior to consumption. According to Sobsey (2002, 36), “alum coagulation and precipitation remove turbidity and other visible contaminants from the water at the household level.” This traditional method has been practiced in many parts of the world for centuries. Chemical coagulation, flocculation and precipitation are another chemical method of water treatment that has been practiced since ancient times. WHO (2011, 1) explained that, “Coagulation or precipitation is any device or method employing a natural or manufactured coagulant or precipitant to coagulate and/or precipitate suspended particles, including microbes, to enhance their sedimentation.” Sobsey explained that this method “enhances the removal of colloidal particles by destabilizing them, chemically precipitating them and accumulating the precipitated material into larger particles that can be removed by gravity settling or filtering.” (Sobsey 2002, 3). This process enables the reduction microorganisms and dissolved solids in the water (Sobsey 2002).[20]

Table 1. Physical Methods for Water Treatment at the Household level. Adapted from Sobsey (2002).

Method	Availability and Practicality	Technical Difficulty	Cost	Microbial Efficacy
Boiling or Heating with Fuel	Varies	Low-Moderate	Varies	High
Exposure to Sunlight	High	Low-Moderate	Low	Moderate
UV Irradiation (Lamps)	Varies	Low-Moderate	Moderate-High	High
Plain Sedimentation	High	Low	Low	Low
Filtration	Varies	Low-Moderate	Varies	Varies
Aeration	Moderate	Low	Low	Low

Similarly, filtration is another ancient method that is used to remove particles and some microbes from the water. Filtration enables the removal of microbes; however, the effectiveness of this method depends on the presence of microbe in the water and the filter quality that is being used (Sobsey 2002). As described by WHO (2011), the “point-of-use water filtration technologies are cloth, fiber filters, membrane filters, porous ceramic filters, carbon filters, and composite filters.” Membrane filtration is used to remove suspended and dissolved solids such as salt and marine microorganisms. The membrane filtration system technology is expensive and used in developed countries. Reverse Osmosis is a type membrane filtration used as pre-treatment of feed water prior to commencing a desalination process. Water treatment technologies are important for desalination technology, especially in the area where rain and ground water are scarce (WIPO 2012). Aboard merchant and naval ships, desalination technology is useful in water production for the crew.[21]

In West Africa, people use locally made filtration cloth to purify water obtained from the river. This traditional method only removes some microbes in the water but does not remove all impurities to make the water safe for human consumption. Figure 6 illustrates the WHO guidance on emergency treatment of drinking water at the point of use. The illustration shows how to treat water with chlorine tablets.

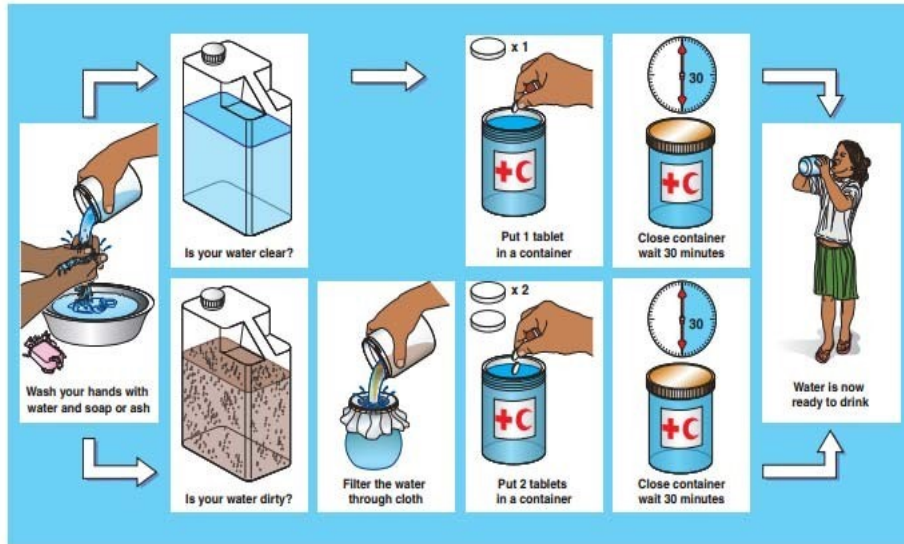

Figure 5. Local Water Treatment Using Chlorine Tablet.

Source: WHO (2013a).

Chemical water treatment is the most effective method to destroy dissolved solids and microorganisms in drinking water (Sobsey 2002). The use of chlorine as an effective disinfectant water agent that was introduced in the late 19th and early 20th centuries (Sobsey 2002). Figure 7 shows a chlorination treatment system where fresh or seawater is introduced into the system and pumped to the hypochlorite solution where the mixture is cycled. The solution inactivates greater than 99.99% of eccentric bacteria and viruses (Sobsey 2002). When the quantity of chlorine added to the water is sufficiently large to ensure that it is not all reduced or combined, a portion of it will remain free in the water (FAO 2011). It is evident that free chlorine effectively inactivates waterborne microbes; however, its use in water treatment reduces the risks of waterborne diseases (FAO 2011).

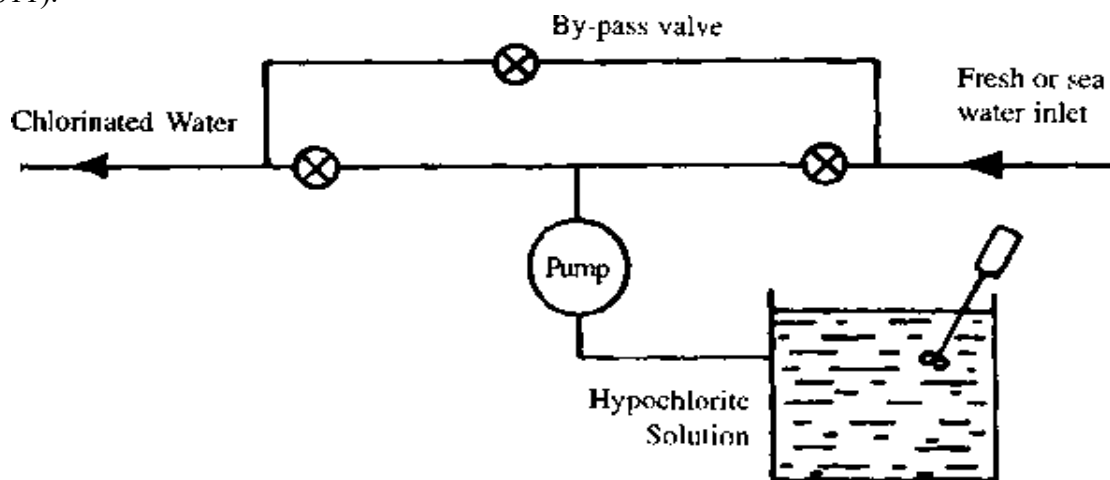

Figure 6. Chlorination Treatment. Source: Food and Agricultural Organization of the United Nations (FAO) (1999).

Sobsey (2002, 47) shows that “Ozone is a strong oxidant capable of rapidly and extensively inactivating a variety of waterborne pathogens,” which includes chlorine-resistant pathogens. The ozone method of water purification is suitable for community. Ozone is not a good candidate for small, individualized household water treatment due to control of each serving is too costly. The system requires a reliable source of electrical power. Figure 8 presents an ozone treatment system. The requirement for the system is a supply of oxygen and operators. Unfiltered raw water is pumped into the system where two carbon filters filter the water. Ozone is now produced by sending pure oxygen through an ozone generator and bubbles it through “a gas diffuser at the bottom of an absorption column in a direction opposite to the flow of raw water” (FAO 2011, 10). This process reduces turbidity of water by breaking down organic constituents.

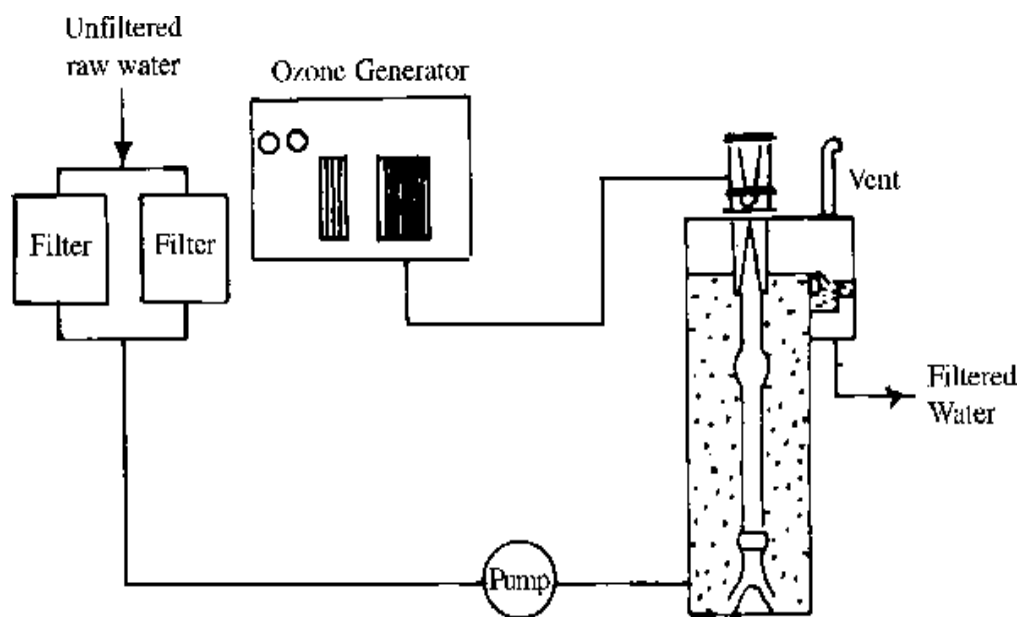

Figure 7. Ozone Water Treatment System. Source: Food and Agricultural Organization of the United Nations (1999).

Another productive and efficient water treatment technology is ultraviolet irradiation, which was introduced in the late 1800s. The system uses short wavelength in the range of 100–280nm UV radiation. This destroys the nucleic acids in the organisms, disrupting their Deoxyribonucleic Acid (DNA), removing their reproductive capability (WIPO 2012). Ultraviolet irradiation has the capability to inactivate greater than 99.99% waterborne chlorine- protozoans at low doses of less than 10MJ/CN² (Sobsey 2002). The system is very “effective for inactivating waterborne pathogens, simple to apply at the household and community levels, and relatively low cost while not requiring the use of chemicals or creating taste, odors or toxic chemical by-products” (Sobsey 2002, 20). Figure 9 shows example of the UV water treatment system. The system is incorporated with low-

pressure vapor lamp or a medium pressure UV lamp. The function of the low-pressure mercury vapor lamp is to produce high-energy UV radiation at 40% efficiency while the medium pressure lamp produces a polychromatic output at 12% efficiency (WIPO 2012). While this system uses UV radiation to inactivate microorganism and dissolved solids in the water, the lamp meets the water. It is enclosed in a quartz sleeve located inside a chamber where the water flows through and exit at the out subsystem (WIPO 2012).

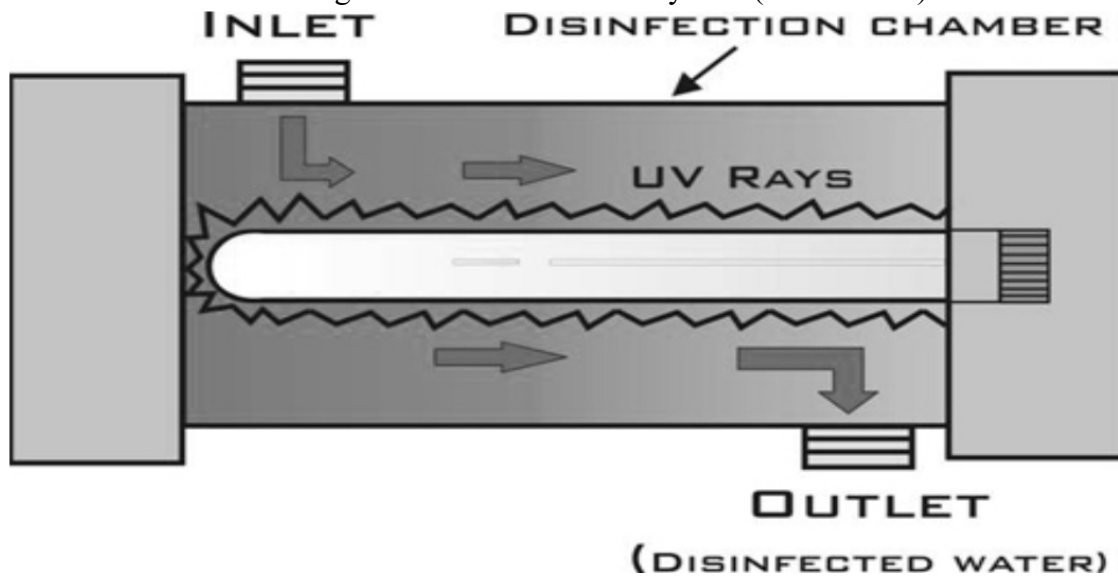

Figure 8. Schematic of the UV Water Treatment System. Source: World Intellectual Property Organization (2012).

2.3 REVIEW OF WATER QUALITY IN WEST AFRICA

This literature review explores water qualities in West Africa to identify and address the capability gaps to fill. In Nigeria for example, pipeline water system (PWS) was being used but are now inoperable and are not channeled to the villages. In the developed cities where PWS are used, water service is not consistent due to the growing urban population. As a result, potable water services are not provided to these areas due to rapidly growing demand for services (Chitonge 2014). People in the urban and rural areas have turned to borehole water system as the main source of water. Chitonge (2014) argued that in order to prevent crisis of access to water, resources used to maintain PWS network to the poorly served area should be a priority in many of the African countries.

A borehole is defined as a hydraulic structure that enables the withdrawal of water from an aquifer. The current BWS utilizes natural aquifer filtration. Currently, it is not incorporated with filtration, monitoring, and disinfectant systems. World Health Organization (2013b) evaluated that high concentrations of chemical compounds such as arsenic and fluoride, which originate from natural sources affect millions of people in the world. This is the reason a dependency on only the natural filtration of the borehole water system is not adequate for human consumption.[24]

In Nigeria, Adelekan (2010) assessed the quality of water supply from different wells in order to ascertain the contamination that exists in the well water in Ogun State. Water samples collected were checked for odor, color, and taste. The samples were analyzed for PH, total dissolved solids, total hardness, total chlorine, free chlorine and, other chemical compounds. The study concluded that the PH values of the samples tested were not within the WHO recommended range of 6.5–8.5 for drinking water. Meanwhile, the WHO guidelines were met for total solids and hardness of the water (Adelekan 2010). These findings were helpful towards the design and analysis for a water purification system that will combat the presence of these metal compounds in the water.

result of this test concluded that there were metal oxides in the water and the WHO standard was not met. With water purification system, the presence of these metals in the water would be monitored and treated before water usage

In West African countries, there is scarcity of water supply both in the rural and urban areas. In Nigeria for example, water supply in the urban area has diminished, and the quality of water is questionable (Ezeabasili, Anike, and Okonkwo 2014). As a result, many households have invested in private borehole water system as a means of avoiding the intermittent water supply from the public PWS. According to Ezeabasili, Anike, and Okonkwo (2014), the intermittent water supply in the urban areas is due to lack of operation and maintenance of the PWS. However, this study would draw on the work of Ukpong and Okon (2013) in the “Comparative Analysis of Public and Private Borehole Water Supply Sources in Uruan Local Government Area of Akwa Ibom State Nigeria.”

One of the key sources of BWS contamination is thought to be from building underground septic tanks and soak-a-ways (soak pit) too close to the boreholes. Most of the West African countries do not have a central wastewater treatment system. Homeowners are compelled to build underground soak-a ways in order to dispose of the domestic waste (Fubara-Manuel and Jumbo 2014). Underground septic tanks and soak-away located at short distances from borehole water sources could damage and leak into the water system causing environmental damage (Fubara-Manuel and Jumbo 2014). Fubara-Manuel and Jumbo (2014) investigated three boreholes and septic tanks that were 6m and 9m apart.. From the sample results, the PH value met the WHO requirements regardless of the distance between the boreholes and the septic tanks. The PH value showed the water being acidic but within limit. Meanwhile, the third borehole was determined to have the highest coliform contamination indicating that the water was not good for human consumption because it was contaminated by human waste from the septic tank that was 6m away (Fubara-Manuel and Jumbo 2014).

In another development in Ejigbo, Osun State of Nigeria, Emmanuel and Bamidele (2013) studied the sustainability of borehole water schemes in the rural area. The team used a systematic random sampling method to collect data from over 250 questionnaires. The characteristics of their data were from boreholes, their functions, and agencies that provided the system (Emmanuel and Bamidele 013). Using descriptive and regression statistical data analysis, different functionalities of boreholes in the area revealed that

over 36 boreholes were in poor serviceable condition out of 64 boreholes that were evaluated. Consequently, 28 of 64 boreholes were functioning well at the time data was collected (Emmanuel and Bamidele 2013). According to Emmanuel and Bamidele (2013), lack of proper maintenance of the BWS was because of the poor socio-economic characteristics of respondents and monitoring group by donor agencies.

While lack of maintenance of the BWS affects its sustainability as presented by Emmanuel and Bamidele (2013), Yong, Mulligan, and Fukue (2015) emphasized that the infiltration and water runoff are the causes of the presence of contaminants in the ground water. The order has to be directed toward eliminating or mitigating the sources of contamination of water resources” (Yong, Mulligan, and Fukue 2015, 77). Nitrates in the soil could leach and enter in the borehole water system due to heavy rainfall. This may result in the contamination of the borehole system, which will require treatment. Nitrate for example, is present in the water due to mineralization of chemical compounds in the soil (Gilli, Mangan, and Mundry 2012).[28]

In summary, the literature survey showed that dependency on only natural filtration of ground water is not sufficient for human consumption. Clearly, water purification system may also be used to purify rainwater in areas of the region where access to borehole water system is scarce. Studies show that most of the borehole water systems in West Africa lacked proper maintenance. Research conducted proved that the BWS is more cost effective, efficient, and sustainable than other water sources. A modified borehole water system will be able to meet capability gaps of monitoring and detection of chemical compound, filtering, and disinfection of water. Based upon this literature review, a purification system for the BWS appears to be the most reliable source of a continuous high quality water supply for the local population as well as U.S. forces operating in West Africa.[29]

CHAPTER -3

OPERATIONAL ANALYSIS AND USER NEEDS

3.1 NEEDS ANALYSIS

Safe and good quality water system is critically important in West Africa for U.S. forces that may operate there in the future. The author grew up in West Africa and knows from personal experience that the borehole water system lacks a purification process before consumption. Based on his personal knowledge having lived there, there is need for a system that will purify and disinfect water from the current borehole water system in West Africa.

- The system needs to be able to provide purified water for 2,000 soldiers or a village of 2,500 people.
- The system needs to have low operating efficiency such as electric cost per gallon of water purified.
- The system needs to have high water production rate for allocation of enough water for 2,000 soldiers or a village of 2,500 people.
- The system needs be low cost, low maintenance, easy to use, and able to produce safe drinking water.

With the identified need of the current water system in West Africa, Figure 10 shows a simplified needs and opportunities analysis diagram that depicts the sequence of the operational analysis and user needs process. In this model, the system deficiencies or capability gaps (monitor, filtration, and disinfection subsystems) are recognized, which calls for technology improvement. This process would follow user needs determination resulting in operational objectives for a new or improved system. The operational analysis process would be the next step, which periodically triggers a functional analysis based on a set of operational requirements (Coolahan 2012). The water system modification process would be based on these steps to complete the operational analysis and user needs.

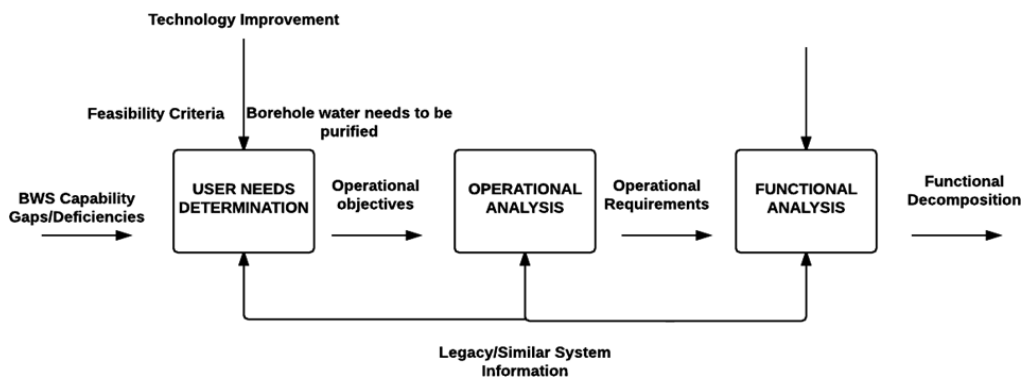

Figure 9. Simplified Needs and Opportunities Analysis Diagram.
Adapted from Coolahan (2012).

3.2 OPERATIONAL REQUIREMENTS

The capability gaps and technical approach to design the water purification system have been defined in the objective and problem statement section. It is now necessary to translate them into a set of operational requirements to identify the objectives of the water system and how well it will perform in its intended environment. The water system requirement analysis defines functional and performance requirements based on the water system capability gaps. This process is “performed iteratively with the[33] functional analysis in order to optimize performance requirements for identified functions, and to verify that synthesized solutions can satisfy customer requirements” (DAU/DSMC 2001, 36).

1. High-Level User Requirement

The system needs to be capable to pump water from the borehole water source, filter, purify, store, and disinfect water prior to delivery to the consumers. The high-level operational requirements of the water system are affordability, easy to use and maintain, and the capability for operation without need for a continuous external power supply. The overall design and analysis of the water purification system is estimated to be less than \$50,000.

2. System Size

According to the *Marine Combat Water Survival Manual* (2002), each soldier operating in a high temperature environment is expected to consume at least 2.6 gallons of drinking water daily. The size of the water purification system is determined for a combined Battalion of 2,000 soldiers. For each of the 2,000 soldiers to consume a daily requirement of 2.6 gallons of water, about 5,200 gallons of water will be required by the troops. Using the required 2.6 gallons of water per person in a village of 2,500 people will amount to 6,500 gallons of water per day. Meanwhile, to prevent water shortage due to equipment breakdown and to increase potable water usage due to excess production, 10,000-gallon potable water tank would be needed. Therefore, the capacity of the water tank and the production rate per day (10,000 gallons per day) would be more than enough for a village of 2,500 or a combined battalion of 2,000 soldiers. For a production rate of 10,000 per day, this means that the water purification system must produce approximately 417 gallons of water per hour.[34]

3. Operational Concept

The proposed water system shall be situated in a village in West Africa where the

U.S. troops are expected to operate in the future. The location shall be close to other African villages that will benefit from the system. It is anticipated that the water system

will be shipped from the United States to West Africa and expected to be operational within one year. The water system will have components that will deliver and store purified water. Based on the user needs and system size, the water purification system will be able to produce 7,000 to 10,000 gallons of water per day.[35]

The system is expected to operate 20 hours per day and the remaining four hours will be used for minor maintenance such as system flushing/cleaning, post operation inspection, daily and turn around inspection, and parts replacement. The system shall be operated by the U.S. forces' water technicians throughout the duration they will operate in West Africa. Thereafter, the local technicians will be trained to operate and maintain the system.

4. Proposed Maintenance Concept

The proposed maintenance concept of the water system evolved from the definition of the operational requirements. The system maintenance level shall be organizational maintenance where the users will perform all the corrective, preventive, and conditional maintenance. It is not expected that the water system will require major maintenance. The system maintenance will be simple which includes visual inspection, operational checkout, external adjustments, removal and replacement of some components.

United States forces will have on-hand pre-expended parts bins during deployments, to reduce difficulty to access of spare parts. In the event where there is need for spare parts, parts may be obtained from local dealers or shipped from the manufacturers to the military bases in the United States. In addition, the water system parts will be in the DOD stock system for easy ordering and faster shipment to West Africa.

5. Environmental Factor

The proposed water system shall be fully operational in an environment with temperature ranging from 70 to 85 degrees and 84 to 88% humidity. The system shall be able to withstand wind speed of 40km/h during Harmattan season. Harmattan is a dry wind that blows from northeast in the Western Sahara that occurs from December to March. In the event of heavy winds during Harmattan season, the water system shall be able to withstand any shock and vibration during water flow.

6. System Reliability

The operational availability (A_o) for the overall water system shall be 99.9%, Mean Time to Failure (MTTF) of less than 10,000 hours, failure rate (λ) of 0.0001

failure/hour, Mean Time Between Maintenance (MTBM) shall be greater than one year, and the maintenance downtime (MDT) shall be less than one hour.[37]

3.3 FUNCTIONAL ANALYSIS

While the operational analysis illustrates what the water system needs to do in order to accomplish its operational tasks, functional analysis shows more detailed analysis of the functionalities required of the system to meet its intended function. The functional description of the water system “serves as a basis for identification of the resources necessary for the system to accomplish its tasks” (Blanchard and Fabrycky 2011, 100). Functional analysis is described as “an iterative process of translating system requirements into detailed criteria and the subsequent identification of the resources required for system operation and support” (Blanchard and Fabrycky 2011, 100). The intent of this process is to look at the details of “what” the water system must do and not “how” the system will do it. In addition, the system requirement will be “broken down to the subsystem and down to the hierarchal structure as necessary in order to identify input design criteria and constraints for the various elements of the system” (Blanchard and Fabrycky 2011, 100). For this thesis and the purpose of the water system, functional analysis shall involve the functional decomposition of the system. The purpose is to identify and decompose the vital functions of the water system, which will result in a list of functions, and sub-functions required of the water system to close the capability gaps.[38]

1. Functional Hierarchy

The functional decomposition enabled the creation of list of functions and sub-functions required for the water system. The list of the system functions will now be organized into meaningful information. One useful method of organizing these functions and sub-functions is the functional hierarchy. Figure 12 presents the functional hierarchy of the water system. In the Figure, the water system is defined according to its functional terms and then decomposed from top-level functions into sub-functions. Each of the functions of the water system is represented by a block diagram and described in terms of inputs, outputs, and interface requirement.

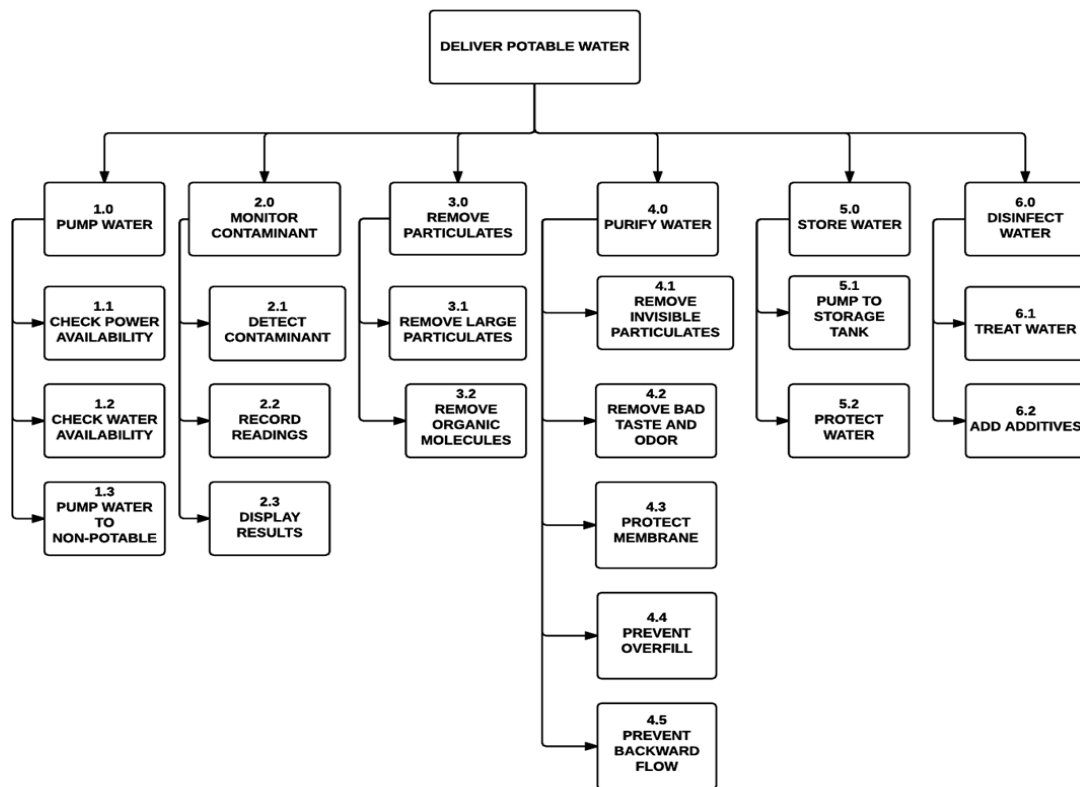

Figure 10. Functional Hierarchy of the Water System (SV-4).

2. Description of the Water System Functions

The functional description allows a deeper understanding of the functionalities of the water system and describes the system functions that are presented in the functional hierarchy in Figure 12. The following are the list of all the main systems and sub-systems that will be supporting the water purification system. In the list, the top two levels of the functional hierarchy are discussed.[39]

Pump water to the system: The purpose of the water pump is to pump water from the borehole water source to increase water pressure that passes through the water purification system. The pump will be able to turn the itself ON/OFF when the tank is over pressurized.

Check power availability: The water pump will need electrical power to operate. Prior to starting the pump, the pump will sense for the presence of electrical power. The water system shall solely operate with electrical power to pump water to the tanks.

Check water availability: The pump will operate when the feed water flows through it. In order to conserve energy, the pump will verify the presence of water flowing through the pump to operate.

Pump non-potable water: The water pump will pump untreated water to the non-potable water tank used for laundry, shower, and cleaning.

Monitor presence of contaminant: Water flows through the monitor/detector system

where the water is cycled for presence of contaminant. The system will need to monitor and stay abreast of environmental conditions. It will be able to conduct self-diagnostic test when faulty.

Detect contaminants in the water: The system will detect the presence of contaminants in the water during the water-cycling period.

Record water contamination levels: Once the presence of chemical compound in the water is detected, the monitor/detector system store the degree of contamination. Based on the level of contamination, it will indicate green, orange, or red light. The green light indicator shows that tolerable or no amount of contaminants is detected and no additional treatment may be necessary. The orange light cautions the user of larger level of contaminants in the water while red indicates that additional water treatment is required.

Display results water contamination: The display monitor displays the level of water contamination on the screen for the system operator to see whether additional treatment of the water is required.

Remove particulates of matter in the water: The first, second, and third stages of the pre-filter assemblies will perform this function. The three filters enable the removal of suspended solids and particulates from the water.

Remove large particulates in the water: The sediment filter, which is the first stage of the pre-filter subsystem, shall be used to remove solid particles such as sand silt, mud, floating particulates and dirt.

Remove organic molecules: The second and third stage of the pre-filter will be used to remove chlorine in the water. The filter is designed to remove bad taste and smells that may be present in the water.

Purify water: The membrane filter is the most effective of the filters and capable of removing up to 95% of total dissolved solids of 0.0001 microns in the water.

Remove visible particulates from the water: The particulates of matter that are invisible to the human eye are removed. The impurities removed are bacteria, viruses, metal compounds, and insecticides found in the ground water.

Remove bad taste and odor: To remove taste and odor from the water in the storage tank. The filter removes molecule residue from the water product.

Protect membrane filter: System over pressurization reduction of the membrane is needed to prevent it from being ruptured.

Prevent overflow: Able to shut-off water to prevent excess water from entering the membrane. When the water level drops in the tank, tank will open to allow water through the membrane.

Prevent backward flow: To prevent the backward flow of treated water from the potable water storage tank from flowing back to the system.

Store water: To store purified water and/or rainwater and used to harvest rainwater. The second potable water tank maintains the supply of purified quality water in the tank when it is needed by the troops. The potable water tank prevents over pressurized in the tank when it is full.

Pump water from storage tank: To pump water from the storage tank to the

consumers. The pump shall automatically start when water is needed and stops when the pump runs dry.

Protect water from particulates: The storage tank shall provide airtight protection of the water against leaks and pollution.

Disinfect water: Disinfection system inactivates any microorganisms that passed through purification system.

Treat water: To kill microorganism in the water.

Add additives to the water: To dispense water additives when required.

3.4 Functional Flow Block Diagram

While the functional hierarchy is useful in breaking down high-level functions and sub-functions required of the water system, it does not adequately display these sub-functions in a logically sequential manner. Meanwhile, one tool to use to understand the system's functions and architecture is the Functional Flow Block Diagram (FFBD). The FFBD shows the sequential manner to perform the functions of the water system using a flow chart (NASA/SP 2007). It presents the sequential relationship of all functions, which the water system will accomplish. For the water system FFBD shown in Figure 13, a circle is used to show a summing gate used when AND/OR gate is present in the FFBD. The AND gate "indicates parallel functions and all conditions that must be satisfied to proceed to the step of the water purification process" (DAU/DSMC 2001, 50). Additionally, "an OR is used to indicate that alternative paths can be satisfied to proceed. These symbols are placed adjacent to lines leaving a particular function to indicate alternative paths and must be carried out in order to continue to the next process" (DAU/DSMC 2001, 50).

The FFBD for the water system begins from the borehole or rainwater and enters into a loop process, which continuously loops as it completes each water purification cycle. It would then enter an AND gate which goes into a parallel functions of pumping water, monitoring contaminant, removing particulates, and purifying water. Each of these high-level function will enter into its specific AND gates for the start of the water purification process. The electric power is provided to the pump-to-pump water from the borehole system. Prior to this event, the pump checks simultaneously to ensure of the availability of power and water. These operational checks will be conducted before starting of the pump. The pump would first pump water to the non-potable water tank for laundry, shower, and cleaning. Next, the presence of contaminants in the water is monitored. This function will detect whether contaminants are present, record the readings, and display data to the system monitor. While monitoring presence of contaminants in the water, the system will conduct a diagnostic self-test, check the level of contaminants, and indicate the appropriate light based on the level of contaminants in the water.

In the purification module, water pressure is provided to the system. The pre-filter removes particulates from the water and enters an AND gate which goes into a parallel

function of removing large particulates and organic molecules respectively. Water enters into parallel function to remove invisible particulates as well as bad taste and odor. The system now goes through a sequence of shutting off water when the tank is full to protect the membrane from being ruptured and to prevent backward flow of treated water to the system. The pump now pumps water and stored it in the storage tank, which will provide airtight protection and monitor water pressure. The water pump in the storage tank is water-cooled. The purified water enters into disinfection process where the disinfection system provides UV energy. It will conduct UV treatment of the water and add additives as appropriate to replenish the minerals that may have been lost in the water during the purification process. System will continue to loop and the water purification process continues until the storage tank is full. The loop sequence will stop once the cycles are completed. Potable water will now be available for the consumers.

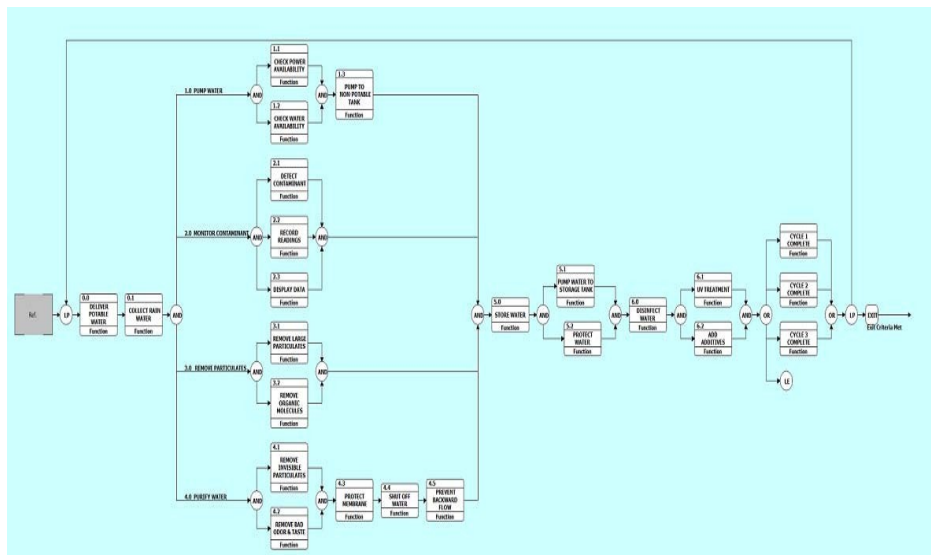

Figure 11. Water System FFBD.

As shown in Figure 11, the water system FFBD shows the logical sequence of what must happen during the water purification and treatment process; but it does not show a time duration to functions and between the functions of the system. In order to understand the time-critical requirements and the detail defining durations of various functions, a time line analysis (TLA) is used.

Figure 14 shows the TLA result of the water system FFBD. CORE software has the capability of simulating a FFBD without need for an input data. The time that is required to perform the water system functions and its sub-functions are demonstrated on a bar chart depicting how the timelines relate to each other. The TLA is used simultaneously with FFBD to capture the duration and sequence of the function of the water system (NASA/SP 2007). For the simulation in Figure 14, it took approximately

650 units of time to complete the water purification process of six cycles.

3.5 Timeline Analysis.

The time line analysis process of the first cycle began from 0 second and completed at time 110 minutes. The second process started again at 110 minutes and completed the cycle at 215 minutes. At 225 minutes, the third cycle commenced and went through the purification process again and completed at time 330 minutes. Furthermore, the fourth cycle started at 340 minutes and ended at 425 minutes. Similarly, the fifth cycle started at 450 minutes and ended at 530 minutes. Finally, the sixth cycle commenced water purification at time 560 minutes and ended at 650 minutes once the exit criteria were met. From the need analysis, the water purification system will produce approximately 417 gallons of water per hour for a production rate of 10,000 gallons per day. Given the 650 minutes for the system to go through six water production cycles, the system produced approximately 4,514 gallons of water within 10 hours 23 minutes. This means that if the system operates for 20 hours in a day as required, it will have produced[41] about 9,028 gallons of water, meeting close to the user need of 10,000 gallons of potable water availability per day.

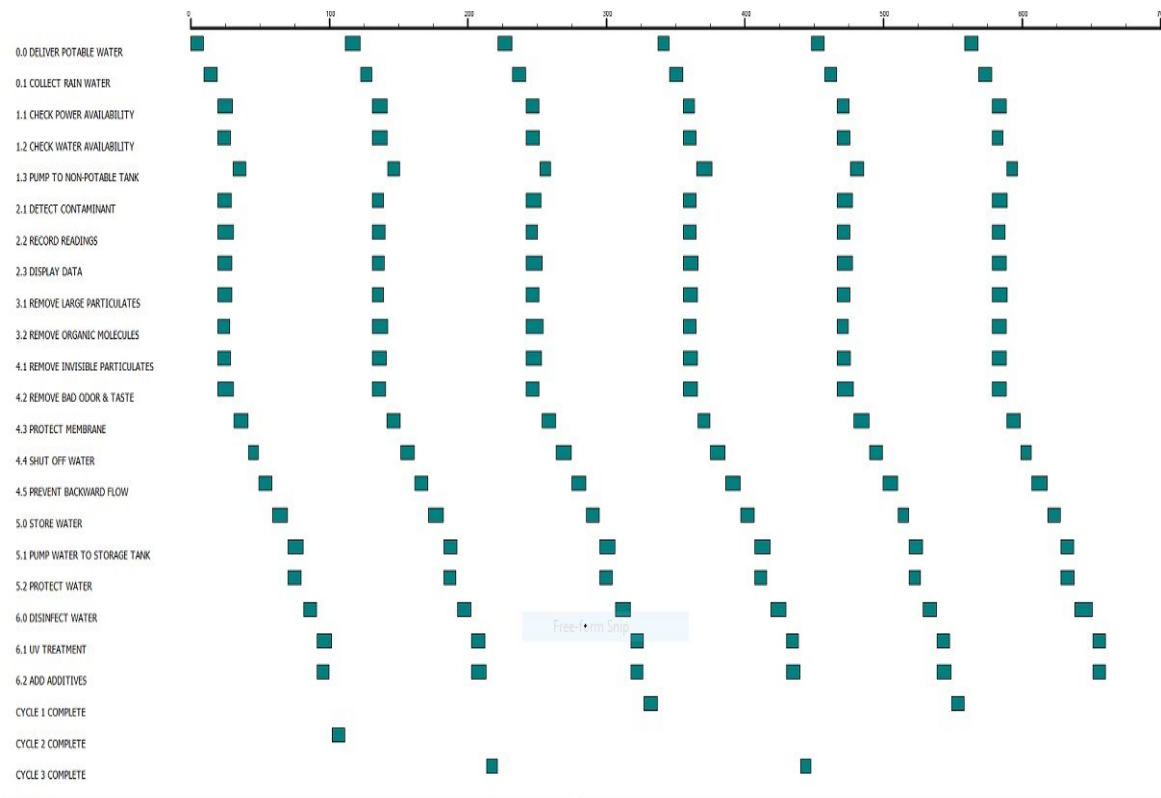

Figure 12. Time Line Analysis for the Water Purification Operation

3.6 LIST OF SYSTEM REQUIREMENTS

The system requirements listed in Table 3 are based upon the functional decomposition of the water system. These components would be used to modify the BWS in order to meet the capability gaps in the area of detection and monitoring of chemical compounds, filtering, and disinfection. From an innovative perspective of the water system, the non-functional requirements will enable the identification and description of the constraints such as system reliability, maintainability, interoperability, and usability. It further demonstrates traceability from the physical components back to the specific requirement and user needs.

Furthermore, each technical specification is justified in the rationale column to enhance clarity. The specifications have their associated functions, which can be traced back to the established functional decomposition.[42]

3.7 TECHNOLOGY FEASIBILITY

Operational and technical feasibility study of the water system is to identify and determine the possible design approaches or an alternative that could be selected in order to meet the user need for a new system (Blanchard and Fabrycky 2011). From an innovative perspective of the water purification system, this study evaluated different feasible approaches to determine the most desirable water purification system that met the capability gaps in the area of detecting and monitoring of chemical compound, filtering, and disinfection of water. Furthermore, the most desirable functional areas of the water system that were investigated are system cost, production rate, usability, and safety criteria. The BWS is inefficient for U.S. troops should they operate in West Africa in the future due to the current capability. Therefore, a cost effective system that will provide safe drinking water to U.S. forces operating in West Africa is required.

During this design and analysis study, several commercial off-the-shelf (COTS) water purification systems and components were investigated to determine the preferred system that would be used to fill the capability gaps. The Pugh Matrix method was used to determine the appropriate water purification system for the BWS in West Africa. Pugh Matrix allows a “comparison of several design concepts selection using a scoring matrix” (Stevens 2015, 4). The three systems that were considered are Modified Reverse Osmosis System (MROS), Water Distillation System (WDS), and the status quo (Contracted Water Supplier (CWS)). The benefits under consideration include operating efficiency, system cost, production rate, and usability and safety. The most important benefit of the water system alternatives is the system cost while usability is the least important attribute.

- **Operating Efficiency** is the rate at which the water system consumes resources such as electric cost per gallons.

- **Cost** is the cost of the system and components.
 - **Production Rate** is the gallons of water production per day.
 - **Usability and Safety:** **Usability** is the ease of use of the system to achieve quantified objectives and satisfaction of the customer in a quantified context. **Safety** is the security of the system during operation or transportation of water from one base to the other.
- Modified Reverse Osmosis System (MROS)**

The MROS is a multi-staged water purification system designed to treat over



10,000 gallons of water per day. It is designed to be able to maintain tolerable performance, high recovery rates, low power consumption, easy to use, inexpensive maintenance and operation cost. The water purification system is configured with four pre-filters, six membranes, and four post-filter subsystems. The system overall acquisition cost is expected to be \$13,800. The manufacturer offers a one-year limited factory warranty. Its shipping weight is 500lbs. Figure 15 illustrates a depiction of likely size and dimension of MROS.

Source: U.S. Water Systems (<https://www.uswatersystems.com/us-water-craftromaster>).

Figure 13. A Depiction of size and dimension of MROS.

Contracted Water Supplier (CWS)

The Department of Defense (DOD) contracted private companies to supply potable water to the U.S. troops in Iraq and Afghanistan. In Afghanistan, it cost \$4.69 per gallon to deliver bottled water to soldiers at a daily demand of 5.3 gallons per Marine (Lash 2011). If a total of 20,000 troops were to be served, for example, the cost to deliver bottled water would be \$497,140 per day in Afghanistan (Lash 2011).

Table 4 shows the Pugh Matrix attributes evaluation for three candidate alternatives. The alternatives were evaluated against five criteria. In creating a Pugh Matrix, the Contracted Water Supplier is selected as the “baseline” because it is the method being used to provide potable water to the troops. Each criterion of the baseline has a corresponding quantifiable attribute. The operating efficiency of the status quo is \$756,028 per month. Comparing this amount to the other alternatives (\$100 per month and \$3,300 per month), it can be seen that it was very expensive to deliver potable water

in Iraq and Afghanistan. For the system cost criterion, a gallon of water cost \$1 in Walmart and 2.6 gallons of water is expected to be consumed by a soldier operating in hot environment. Therefore, it will cost \$161,200 per month for a unit of 2,000 soldiers to consume 2.6 gallons of water daily. Meanwhile, the cost to acquire MROS and WDS, which are capable of producing potable water are \$13,800 and \$155,731, respectively.

The production rate of the baseline is over 10,000 GPD while that of MROS and WDS are 10,000 GPD and 6,000 GPD. Both the usability and safety of the alternatives are measured in percent. It is expected that the usability of the baseline is 100% because the soldiers preferred bottled water due to its portability and ease of use. The usability of MROS is estimated to be 90% because the system is expected to perform water purification operation for 20 hours per day while the remaining four hours are used for maintenance. The usability of WDS is expected to be 100% because it is designed to produce about 6,000 GPD. If time is allocated for maintenance without enough water in the storage, there may be shortage of water, which would take several hours to make up.

The safety of bottled water is 90% because it could support bacteria growth in the water if not stored in a well-ventilated room (Lash 2011). The safety risk level of both MROS and WDS are 98% considering possibility of contaminants in the system if maintenance is not performed properly. From the analysis in Table 4, it can be seen that MROS has the highest attribute.

Table 2. Alternative Data

PUGH EVALUATION MATRIX		ALTERNATIVES		
CRITERIA	UNITS	BASELINE (IRAQ)	MROS	WDS
Operating Efficiency	\$/GAL	\$756,028 (per month)	\$100 (per month)	\$3,300 (per month)
System Cost	\$/GAL	\$161,200 (per month)	\$13,800 (cost of system)	\$155,731 (cost of system)
Production Rate	GPD	>10,000 GPD	10,000 GPD	6,000 GPD

Usability	%	100%	90%	100%
Safety	Risk level in %	90%	98%	98%

In Table 5, each criterion is rated against the corresponding baseline as follows: “+” Alternative is Better than the Baseline concept

“S” Alternative is Same as the Baseline concept

“-” Alternative is Worse than the Baseline concept

The Baseline was compared with the alternatives because it is currently being used. The Baseline column is marked “DATUM” since it is not required to be scored. For each candidate alternative, the total score was calculated by summing the number of +s, Same, and -s. The MROS appeared to have the highest score of 4 and would be the preferred water purification for the BWS.

Table 3. System Selection Using Pugh Matrix.

Pugh Matrix				
Concept Selection Legend		BASELINE (IRAQ)	MROS	WDS
Better	+			
Same	S			
Worse	-			
Key Criteria				
Operating Efficiency		D	+	+
Cost		A	+	-
Production Rate		T	S	-
Usability		U	+	S
Safety		M	+	+
Sum of Positives			4	2
Sum of Negatives			0	2
Sum of Sames			1	1
TOTALS			4	0

Adapted from Alex Sugimoto (<https://alex-sugimoto.squarespace.com/s/Pugh-Matrix-Template.xls>) (2016).

3.8 COST ANALYSIS OF THE WATER PURIFICATION SYSTEM

The feasibility analysis was beneficial in determining the most desirable purification system. Cost analysis of the water system will further aid in determining and comparing the benefits and costs of each of the alternatives to meet the system objective. Cost Analysis is the prediction of the anticipated expenditures associated

with each of the water system alternatives (Boensel 2016). The water system planning horizon is 15 years. All the feasible ways to satisfy the objective has been considered; however, three alternatives to be considered are the Modified Reverse Osmosis System (MROS), Water Distillation System (WDS), and Contracted Water Supplier (CWS). For the cost analysis of the water system, the time horizon is 15 years and the real discount rate of 1.0% is applied to the costs. The discount rate is published yearly in Office of Management and Budget (OMB) Circular A-94, Appendix C.

Alternative A: MROS

The cost-breakdown shown in Table 6 is a “linear” list whereby the total cost of the MROS was calculated by adding together the costs of all items. The rationale of the cost for each item is shown in Table 6. Table 7 presents the cost analysis summary of the MROS. The MROS has a one-year factory warranty for the components and modules. The total investment cost during the first year is estimated to be \$43,837, as shown in Table 7. The cost of the components and subsystems used to assemble the prototype is \$300. The prototype is categorized as part of research and development (R&D) cost. Since the system is under manufacturer’s warranty for one year and no maintenance is due, the fuel and electricity costs were estimated to be \$3,600 for a total cost of \$47,737 during the first year.

Table 4. Cost Breakdown of MROS

Task Number	Items	Cost	Ratio nale
1.0	Modified Reverse Osmosis System (Investment)		
	(Non-Recurring)		
1.1	Borehole Construction	\$ 3,000	The author constructed a borehole in Nigeria recently. Estimate is based on experience.
1.2	System and components	\$ 13,800	Quote from (www.uswatersystems.com).
1.2.1	Chemical coumpound monitor	\$ 260	Quote from (www.uswatersystems.com).
1.2.2	Disinfectant	\$ 100	Quote from (www.uswatersystems.com).
1.2.3	7.5 KW Solar Grid Power Kit	\$ 9,932	Estimate from (www.mrsolar.com/online-solar-7500-watt-grid-tie-solar-power-system-kit/).
1.2.3.1	Initial Labor	\$ 300	Labor estimate based on author's experience in Nigeria.
1.2.4	Generator Cost	\$ 500	Estimated cost of medium sized generator at Home Depot

			(www.homedepot.com).
1.2.5	Pump	\$ 245	Obtained from (www.uswatersystems.com).
1.2.6	Storage Tanks		
1.2.6.1	Rain Water Tank	\$ 1,000	Tank cost estimate in Nigeria based on author's experience.
1.2.6.2	Potable Water Tank	\$ 1,000	Tank cost estimate in Nigeria based on author's experience.
1.2.6.3	Non-potable Water Tank	\$ 1,000	Tank cost estimate in Nigeria based on author's experience.
1.3	Shipping (20 ft container)	\$ 3,850	Quote from Ship overseas (www.shipoverseas.com).
1.3	Clearing	\$ 2,000	Quote from clearing agent.
1.3.2	Transportation to destination	\$ 500	Estimated transportation cost in Nigeria.
1.4	Training (Per day for 1 day)	\$ 650	Estimated training cost per day.
1.5	Initial Labor	\$ 200	Estimated initial labor cost based on the author's experience.
1.6	Prototype model	\$ 300	Quote from (www.uswatersystems.com) and (www.esewaterproducts.com)
1.7	System protective enclosure		
1.7.1	Building Materials for system enclosure construction	\$ 5,000	Estimated cost for building materials based on author's experience in Nigeria.
1.7.2	Labor for enclosure construction	\$ 500	Labor estimate based on author's experience in Nigeria.
	Operation and service		
	(Recurring)		
1.8	Parts (per year)	\$ 3,665	Quote from (www.esewaterproducts.com).
1.9	Electric Service (per year)	\$ 1,200	Estimated based on the manufacturers advertisement (\$100 per month)
2.0	Fuel (per year)	\$ 2,400	Estimated cost of fuel based on author's experience in Nigeria(\$200 per month).
2.1	Repair cost (per year)	\$ 2,400	Estimated cost to repair system per year (\$200 per month).
	(Non-Recurring)		
			Expected cost of system overhaul

2.2	Overhaul (at year 7 of investment)	\$ 5,000	based on cost of each component.
	Total	\$ 58,802	

The system is expected to be overhauled during the seventh year at the estimated cost of \$5,000. Beginning the following year, after the factory warranty would have ran out, the cost of the components that are to be replaced annually in accordance with manufacturer’s recommendations will increase the operation and support (O&S) cost to \$6,517. Similarly, replacement of the components that are recommended to be replaced biennially will be conducted and the total O&S cost would now be \$9,677. This operation and support process is expected to continue for the entire life cycle of the system. Additionally, the sum of R&D, Investment, O&S, and Salvage value has a NPV of \$157,589.00.

Table 5. Cost Analysis Summary of the MROS

		Cost Summary							
Alternative:	Modified Reverse Osmosis System	Economic Life: 15							
		Program/Project Costs							Real Rate
Year		R&D	Investment	O&S	Salvage	Annual Cost	Discount Factor	Present Value	0.01
Project Year	FY								
0	2016	\$ 300	\$ 43,837	\$ 3,600	\$ -	\$ 47,737	1	\$47,737	
1	2017	\$ -	\$ -	\$ 6,517	\$ -	\$ 6,517	0.99009901	\$6,452	
2	2018	\$ -	\$ -	\$ 9,677	\$ -	\$ 9,677	0.980296049	\$9,486	
3	2019	\$ -	\$ -	\$ 6,517	\$ -	\$ 6,517	0.970590148	\$6,325	
4	2020	\$ -	\$ -	\$ 9,677	\$ -	\$ 9,677	0.960980344	\$9,299	
5	2021	\$ -	\$ -	\$ 6,517	\$ -	\$ 6,517	0.951465688	\$6,201	
6	2022	\$ -	\$ -	\$ 9,677	\$ -	\$ 9,677	0.942045235	\$9,116	
7	2023	\$ -	\$ 5,000	\$ 6,517	\$ -	\$ 11,517	0.932718055	\$10,742	
8	2024	\$ -	\$ -	\$ 9,677	\$ -	\$ 9,677	0.923483222	\$8,937	
9	2025	\$ -	\$ -	\$ 6,517	\$ -	\$ 6,517	0.914339824	\$5,959	
10	2026	\$ -	\$ -	\$ 9,677	\$ -	\$ 9,677	0.905286955	\$8,760	
11	2027	\$ -	\$ -	\$ 6,517	\$ -	\$ 6,517	0.896323718	\$5,841	
12	2028	\$ -	\$ -	\$ 9,677	\$ -	\$ 9,677	0.887449225	\$8,588	
13	2029	\$ -	\$ -	\$ 6,517	\$ -	\$ 6,517	0.878662599	\$5,726	
14	2030	\$ -	\$ -	\$ 9,677	\$ -	\$ 9,677	0.86996297	\$8,419	
Total		\$ 300	\$ 48,837	\$ 116,958	\$ -	\$ 166,095		\$157,589	

Alternative B: WDS

The cost breakdown for each item during the acquisition period of the WDS is shown in Table 8. Each cost of the WDS item is justified as illustrated in Table 8. The WDS has one-year warranty for all components and its expected life cycle is 15 years. The investment cost of the system during the first year will be \$188,018 as shown in Table 9. Due to the manufacturer’s warranty, any repairs

performed during this period would be paid by the manufacturers. Therefore, electricity and fuel costs will be \$17,700 during the first year of O&S of the system. The annual cost for the first year was estimated to be \$205,718. Beginning the following year, the cost of spare parts, generator repair, and system repair were added to the fuel and electric usage costs for a total O&S cost of \$57,900. The system is expected to be overhauled during the seventh year at the cost of \$50,000. This overhaul maintenance will increase the annual cost to \$107,900. WDS NPV was calculated to be \$1,005,268.[43]

Table 6. Cost-Breakdown of WDS

Task Number	Items	Cost	Rationale
1.0	Water Distillation System (Investment)		
	(Non-Recurring)		
1.1	Borehole construction	\$ 3,000	The author constructed a borehole in Nigeria. Estimate is based on experience.
1.2	VC6000 Commercial Distiller	\$ 155,731	Quote from (www.uswatersystems.com).
1.2.1	Chemical compound monitor	\$ 260	Quote from (www.uswatersystems.com).
1.2.2	Disinfectant	\$ 100	Quote from (www.uswatersystems.com).
1.2.3	Water pump	\$ 245	Obtained from (www.uswatersystems.com).
1.2.4	Potable water tank	\$ 1,000	Tank cost estimate based on author's experience in Nigeria.
1.2.5	7.4 KW Solar Grid Power Kit	\$ 9,932	Estimate from (www.mrsolar.com/online-solar-7500-watt-grid-tie-solar-power-system-kit)
1.2.5.1	Labor	\$ 300	Labor estimate based on author's experience in Nigeria.
1.2.6	Generator cost	\$ 500	Estimated cost of medium sized generator at Home Depot (www.homedepot.com).
1.2.7	Initial labor	\$ 200	Estimated initial labor cost based on the author's experience in Nigeria.
1.3	Shipping (per 40 ft container)	\$ 5,000	Quote from Ship Overseas (www.shipoverseas.com).
1.3.1	Clearing	\$ 2,000	Quote from clearing agent.
1.3.2	Transportation to destination	\$ 500	Estimated transportation cost in Nigeria.
1.4	Training (per day for 5 days)	\$ 3,750	Quote for initial training per day (\$695/pay) from (www.h2olabs.com).
1.5	Building Materials for system enclosure	\$ 5,000	Estimated cost for building materials based on author's experience in Nigeria.
1.5.1	Labor for enclosure construction	\$ 500	Labor estimate based on author's experience in Nigeria.
	Operation and Service		
	(Recurring)		
1.6	Electric service per day (per month)	\$ 15,300	Based on Quote specification (0.085/US Gallon x 6000 gallons/day x 30 days).
1.7	Fuel cost (per year)	\$ 2,400	Estimated cost of fuel based on author's experience (\$200/month).
1.8	Generator repair cost (per year)	\$ 200	Estimated cost to repair generator per year.
1.9	Parts cost (per year)	\$ 30,000	Annual cost to replace components. Quote from (www.h2olabs.com).
2.0	Repair cost (per year)	\$ 10,000	Estimated repair cost of VC6000/year
	(Non-Recurring)		
2.1	Overhaul (at year 7 of investment)	\$ 50,000	Expected cost of system overhaul.
	Total	\$ 295,918	

Table 7. Cost Analysis Summary of the WDS

				Cost Summary				
--	--	--	--	--------------	--	--	--	--

Alternative: Water Distillation System						Economic Life: 15			
Program/Project Costs									
Year		R&D	Investment	O&S	Salvage	Annual Cost	Discount Factor	Present Value	Real Rate
Project Year	FY								0.01
0	2016	\$ -	\$ 188,018	\$ 17,700	\$ -	\$ 205,718	1	\$205,718	
1	2017	\$ -	\$ -	\$ 57,900	\$ -	\$ 57,900	0.99009901	\$57,327	
2	2018	\$ -	\$ -	\$ 57,900	\$ -	\$ 57,900	0.980296049	\$56,759	
3	2019	\$ -	\$ -	\$ 57,900	\$ -	\$ 57,900	0.970590148	\$56,197	
4	2020	\$ -	\$ -	\$ 57,900	\$ -	\$ 57,900	0.960980344	\$55,641	
5	2021	\$ -	\$ -	\$ 57,900	\$ -	\$ 57,900	0.951465688	\$55,090	
6	2022	\$ -	\$ -	\$ 57,900	\$ -	\$ 57,900	0.942045235	\$54,544	
7	2023	\$ -	\$ 50,000	\$ 57,900	\$ -	\$ 107,900	0.932718055	\$100,640	
8	2024	\$ -	\$ -	\$ 57,900	\$ -	\$ 57,900	0.923483222	\$53,470	
9	2025	\$ -	\$ -	\$ 57,900	\$ -	\$ 57,900	0.914339824	\$52,940	
10	2026	\$ -	\$ -	\$ 57,900	\$ -	\$ 57,900	0.905286955	\$52,416	
11	2027	\$ -	\$ -	\$ 57,900	\$ -	\$ 57,900	0.896323718	\$51,897	
12	2028	\$ -	\$ -	\$ 57,900	\$ -	\$ 57,900	0.887449225	\$51,383	
13	2029	\$ -	\$ -	\$ 57,900	\$ -	\$ 57,900	0.878662599	\$50,875	
14	2030	\$ -	\$ -	\$ 57,900	\$ -	\$ 57,900	0.86996297	\$50,371	
Total		\$ -	\$ 238,018	\$ 828,300	\$ -	\$ 1,066,318		\$1,005,268	

Alternative C: CWS

The bottom-up cost-breakdown for CWS based on estimates is shown for each item in Table 10. Each cost is justified in Table 10 to show how the data was obtained. The DOD contracted private companies to supply water to the U.S. troops while in Iraq and Afghanistan. Using data from that experience, the cost breakdown in Table 10 shows that, the cost of a gallon of water is \$1. It costs \$4.69 to deliver water to the troops. Each soldier was expected to consume about 2.6 gallons of water daily while operating in hot environment. Therefore, the total cost of water consumption for 2,000 soldiers in a day would be \$5,200. However, in a month, the total cost to buy bottled water for the troops would be \$156,000. In a year, it would cost the sum of \$1,872,000. Additionally, it costs a total of \$8,779,680 to deliver water to the troops in Iraq and Afghanistan annually.

The cost analysis of CWS in Table 11 shows that the first year of the initial water supply contract was \$10,657,180. This amount is in addition for the construction of an enclosure that would house the bottled water. O&S cost is not expected during the first year because the initial cost of water and the delivery cost have already been added as part of the investment cost. Subsequent years of the contract would cost the sum of \$10,651,680 annually to supply water to the troops for 15 years. With the given calculations, the NPV of CWS alternative will be \$149,168,463.

The NPV derived from the cost analysis of each design alternative. The NPV of MROS was calculated to be \$157,589 while that of WDS and CWS are \$1,005,268.00 and \$149,168,463 respectively. The NPV shows that it would be more cost-effective to acquire the MROS based on the total cost.

Table 8. Cost-Breakdown of the CWS

Task Number	Items	Cost	Rational
1.0	Contracted Water Supplier (Initial Contract)		
	(Recurring)		
1.1	Bottled water/ gallon/troop/ year)	\$ 1,872,000	\$1/gallon (www.walmart.com) x 2.6 gallons x 2,000 troops x 30 days = \$156,000 per month.
1.2	Water delivery/gallon/day/year	\$ 8,779,680	\$4.69/gallon/day (National Defense 2011) x 2.6 gallons x 2,000 troops x 30 days = \$731,640.00 per month.
1.2.1	Shipping (per 40 ft container)	\$ -	
1.2.2	Clearing cost per container	\$ -	
1.2.3	Labor	\$ -	
1.3	Shelter		
	(Non-Recurring)		
1.3.1	Building Materials for water storage unit	\$ 5,000	Estimated building materials cost based on author's experience in Nigeria.
1.3.2	Labor for storage unit construction	\$ 500	Estimated labor cost based on author's experience in Nigeria.
	Total	\$ 10,657,180	

Table 9. Cost Analysis Summary of the CWS

		Cost Summary				Economic Life: 15			
Alternative: Contracted Water Supplier		Program/Project Costs							
Year		R&D	Investment	O&S	Salvage	Annual Cost	Discount Factor	Present Value	Real Rate
Project Year	FY								0.01
0	2016	\$ -	\$ 10,657,180	\$ -	\$ -	\$ 10,657,180	1	\$10,657,180	
1	2017	\$ -	\$ -	\$ 10,651,680	\$ -	\$ 10,651,680	0.99009901	\$10,546,218	
2	2018	\$ -	\$ -	\$ 10,651,680	\$ -	\$ 10,651,680	0.980296049	\$10,441,800	
3	2019	\$ -	\$ -	\$ 10,651,680	\$ -	\$ 10,651,680	0.970590148	\$10,338,416	
4	2020	\$ -	\$ -	\$ 10,651,680	\$ -	\$ 10,651,680	0.960980344	\$10,236,055	
5	2021	\$ -	\$ -	\$ 10,651,680	\$ -	\$ 10,651,680	0.951465688	\$10,134,708	
6	2022	\$ -	\$ -	\$ 10,651,680	\$ -	\$ 10,651,680	0.942045235	\$10,034,364	
7	2023	\$ -	\$ -	\$ 10,651,680	\$ -	\$ 10,651,680	0.932718055	\$9,935,014	
8	2024	\$ -	\$ -	\$ 10,651,680	\$ -	\$ 10,651,680	0.923483222	\$9,836,648	
9	2025	\$ -	\$ -	\$ 10,651,680	\$ -	\$ 10,651,680	0.914339824	\$9,739,255	
10	2026	\$ -	\$ -	\$ 10,651,680	\$ -	\$ 10,651,680	0.905286955	\$9,642,827	
11	2027	\$ -	\$ -	\$ 10,651,680	\$ -	\$ 10,651,680	0.896323718	\$9,547,353	
12	2028	\$ -	\$ -	\$ 10,651,680	\$ -	\$ 10,651,680	0.887449225	\$9,452,825	
13	2029	\$ -	\$ -	\$ 10,651,680	\$ -	\$ 10,651,680	0.878662599	\$9,359,233	
14	2030	\$ -	\$ -	\$ 10,651,680	\$ -	\$ 10,651,680	0.86996297	\$9,266,567	
Total		\$ -	\$ 10,657,180	\$ 149,123,520	\$ -	\$ 159,780,700		\$149,168,464	

CHAPTER-4

DETAIL DESIGN OF SYSTEM COMPONENTS

4.1 SYSTEM DESCRIPTION

The water purification system comprises of three reverse osmosis subsystems and seven external components. The three subsystems are pre-filter, membrane filter, and post-filter. These subsystems make up the water purification system. The seven external components are pump, power source, monitor/detector, disinfectant, storage tank, non- potable water tank, and borehole. These components will enhance the water purification and treatment process. Figure 17 shows the composition and interactions of the water purification system. This system interface diagram is annotated with operational activities of each of the subsystem and external components showing how they interact with one another to enhance the water purification process.[43]

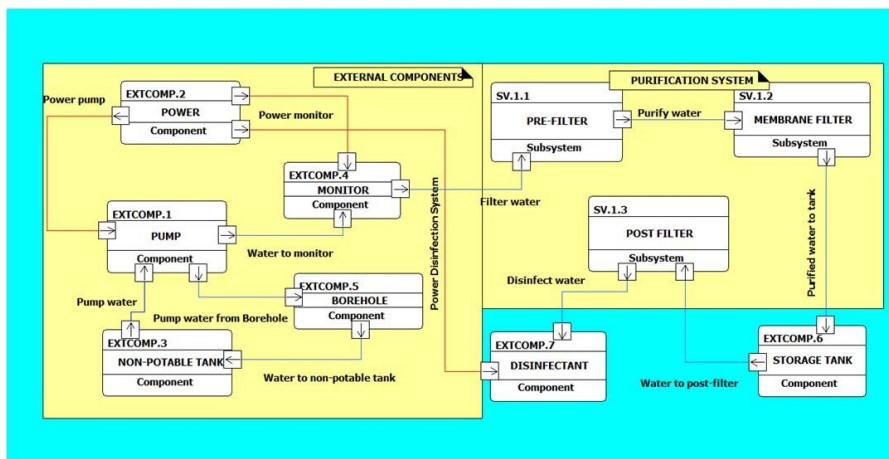

Figure 15. System Interface Diagram (SV-1)

Figure 16 shows the top-level system architecture of the MROS. It describes how various requirements of the system interaction, the system configuration and operational interfaces. The system architecture is derived from the description of the system operational requirements, functional requirements, system technical specification, and the maintenance and support concept. Each of the top-level of the external components and subsystems are further decomposed to the second level.

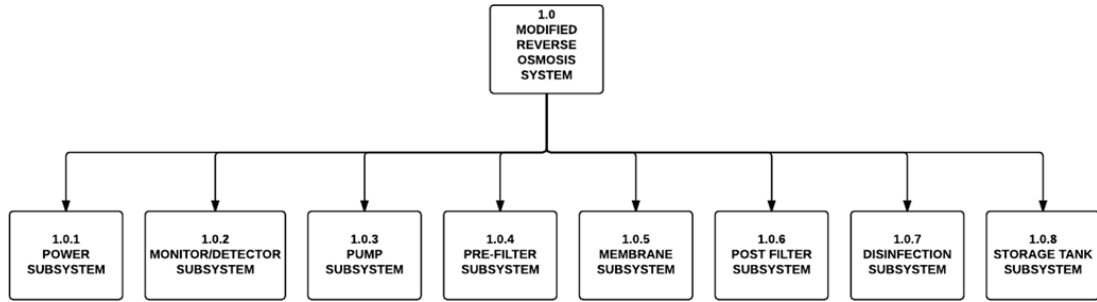

Figure 15. Physical Decomposition Level One for the Water Purification System

Power System

Figure 17 shows the second level of the physical decomposition of the power system. For the purpose of this thesis, there are three power source options: city electricity, solar energy and emergency generator. In West Africa, electric distribution is not consistent. Similarly, there may be scarcity of fuel for the emergency generator. Therefore, there is need for both solar power and emergency generator for a continuous pumping of water from the borehole to the purification system. For a cost effective design, the use of solar power will be optional while an emergency generator is used. The physical decomposition of the solar panel is incorporated to the decomposition of the power subsystem as shown in Figure 17.

Furthermore, the next level illustrates the physical decomposition of the solar panel. For the purpose of the improved water system, the system shall be incorporated and operate by solar panel or electric generator for a continuous pumping of water during the purification process. Due to the constant power loss in most of the West African countries, solar energy and emergency generator shall be the power source for the electric pump.

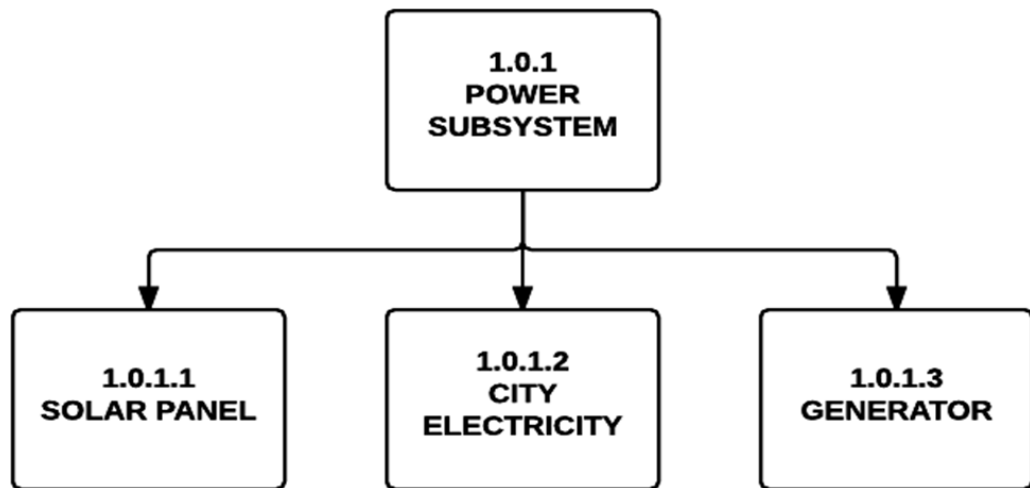

Figure 16. Physical Decomposition Level Two for the Power System

Monitor/Detector System

Figure 18 shows the physical decomposition level two for the monitor/detector system. This subsystem is vital in monitoring and detecting the level of chemical compound in the water prior to start of the purification process. The monitor/detector system consists of display screen, potential hydrogen (PH) detector, recorder, and sensor. Non-potable water will flow through this system prior to the start of water purification. The display screen will display the content of any chemical compound in the water with the aid of the PH detector and then record the values in the system computer memory. It monitors both the feed Total Dissolved Solids (TDS) and product TDS levels to display salt rejection percentage and membrane performance. The monitor/detector system displays the product water TDS and conductivity levels, which are useful in evaluating the performance of the water system (AXEON 2013). Sensor attached to the monitor is used to obtain the exact chemical compound that are being detected. This will enhance the detection the quantity of fluoride, chlorine, lead, pesticides, nitrates, and sulfates in the water.

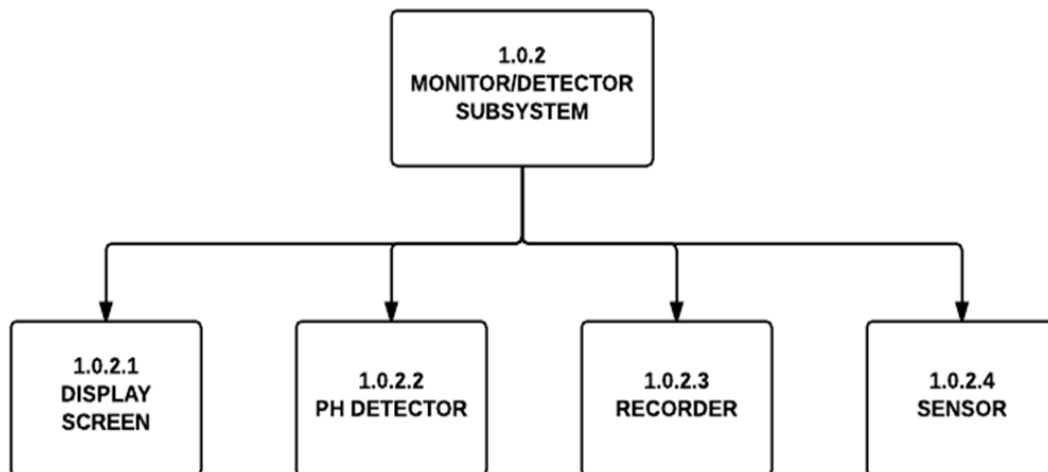

Figure 17. Physical Decomposition Level Two for the Monitor/Detector System

Pump Systems

The MROS does not require electricity to operate, it only needs water pressure to run. The pump system is chosen to pump water from the borehole water source to the water purification system. It consists of both electrical and mechanical pumps as shown in the physical decomposition of the subsystem in Figure 21. Currently, most of the borehole systems use the mechanical pump. The mechanical pump is too slow and takes hours to fill up the potable water tank. An electrical pump is incorporated to the design to speed up the water purification process. When the electrical pump is inoperable, the mechanical pump option will be used to pump water to the water purification system in order to start the purification process. The water purification system will use a pump and motor combination. The motor is available in standard voltage of 220V, 60 Hertz, 3 Phase, and 27 Ampere. The pump type used is a vertical multi-stage centrifugal steel pump. Further, the pump is not to be run dry without sufficient feed water to prevent it from being damaged. The pump is fed with filtered

water to avoid it from being susceptible to sediment and debris.[44]

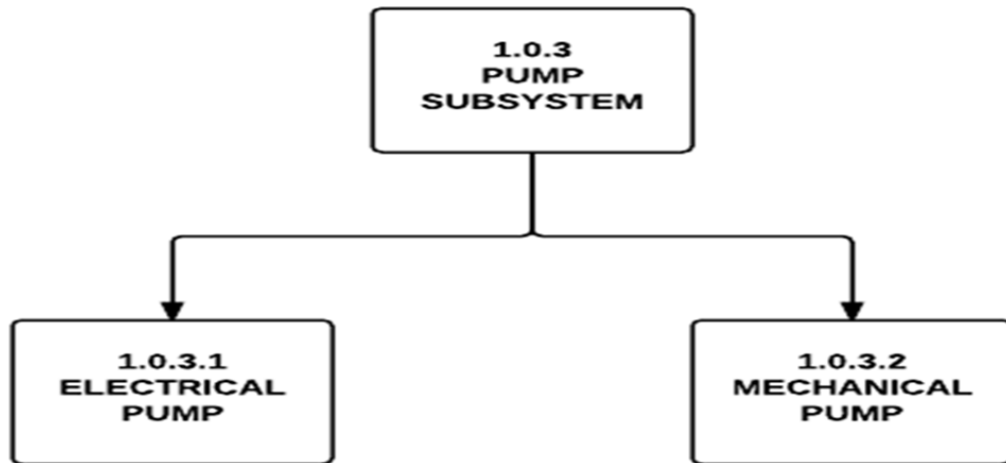

Figure 18. Physical Decomposition Level Two for the Pump System

Pre-Filter Subsystem

The reliability module of the water system is described in detail in Chapter IV, Section C of this report. The pre-filters are supplied with 5-micron sediment pre-filters and two 10-micron carbon block pre-filters. During the purification process, water will flow through these three stages of the pre-filter subsystem before being sent to the membrane subsystem. The two sets of four stages of the pre-filter are designed to remove sediments, silts, and particulate of matter from the water. The pre-filters equally protect the membrane filters from damage while removing all before water goes to the membranes. In addition to the manufacturer filters replacement guidance, the pre-filters are replaced when 10–15 psi differential exists between the two pre-filters (AXEON 2016).

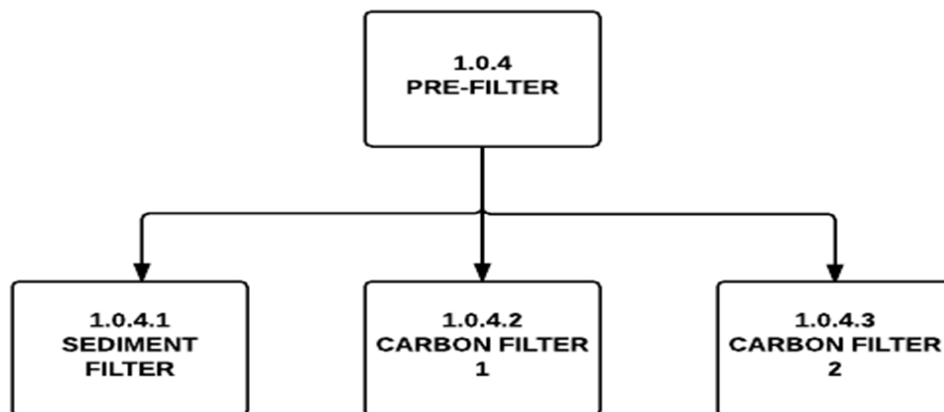

Figure 19. Physical Decomposition Level Two for the Pre-Filter Assembly

Membrane Subsystem

Figure 21 illustrates the physical decomposition level two for the membrane subsystem. The membrane subsystem consists of membrane element, permeate, and pressure vessel. There are 10 membranes, two membranes per vessel for the size of 4040 PPM. The system has a 56% standard recovery rate and nominal salt rejection

rate of 98.5%. membrane elements are preloaded with Polyamide Thin Film Composite (TFC) HF1 High-Flow-Low Energy membrane. The membrane subsystem is important in removing organic substances colloid and bacteria in water. Production rate and recovery rates are based on feed water conditions of 550 PPM TDS at 77 degrees, 8.25 PPM of product TDS and other test parameters. However, the treatment ability of the water system is based on feed water quality obtained from the borehole. High TDS and/or low temperature will significantly reduce potable water production.

The total concentration of TDS that are “rejected by the membrane is expressed as a percentage” (AXEON 2013). For example, the nominal rejection rate of the membranes as specified by AXEON is 98.5%. This means that about 98.5% of the dissolved solid will not be able to pass through the membrane filters. The system is capable of rejecting up to 98.5% Sodium Chloride (NaCl). Percent rejection of the membrane is calculated in order to validate the specified percent rejection TDS in the membrane filter.

$$\% \text{ Rejection} = (\text{Feed TDS} - \text{Product TDS}) / (\text{Feed TDS}) \times 100\% \quad (1)$$

$$= (550 \text{ ppm} - 8.25 \text{ ppm}) / (550 \text{ ppm}) \times 100\% = 98.5\%$$

Similarly, the amount of permeate water that is to be recovered is also expressed in percentage. According to the manufacturer’s specification, the product water flow rate in each membrane is 7.86 GPM while the feed water flow rate is 14 GPM.

$$\% \text{ Recovery} = (\text{Product Water Flow Rate}) / (\text{Feed Water Flow Rate}) \times 100\% \quad (2)$$

$$= 7.86 \text{ GPM} / 14 \text{ GPM} \times 100\% = 56\%$$

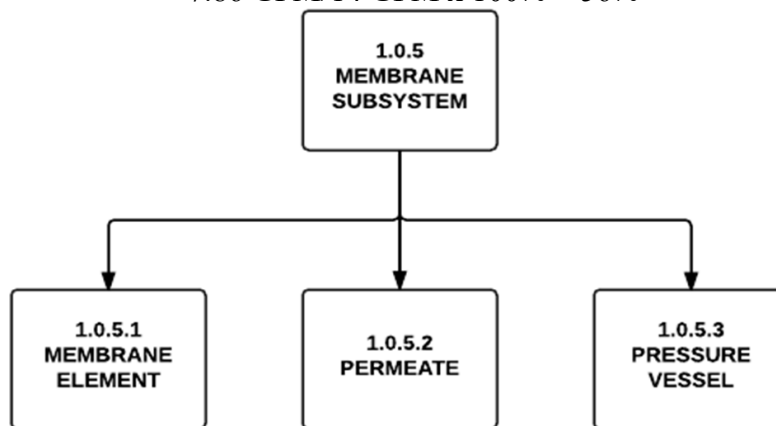

Figure 20. Physical Decomposition Level Two for the Membrane Subsystem

Post-Filter Subsystem

The water system is configured with two 10-micron carbon block and two-micron ultra-pure post filters at the final stage of water purification process prior to disinfection of the water. This configuration is to filter impurities or contaminants in the water before consumption. The post filters are designed to remove chlorine particles and pesticides to improve the taste and odor of the water. Figure 24 shows the physical decomposition of the post filter subsystem.[45]

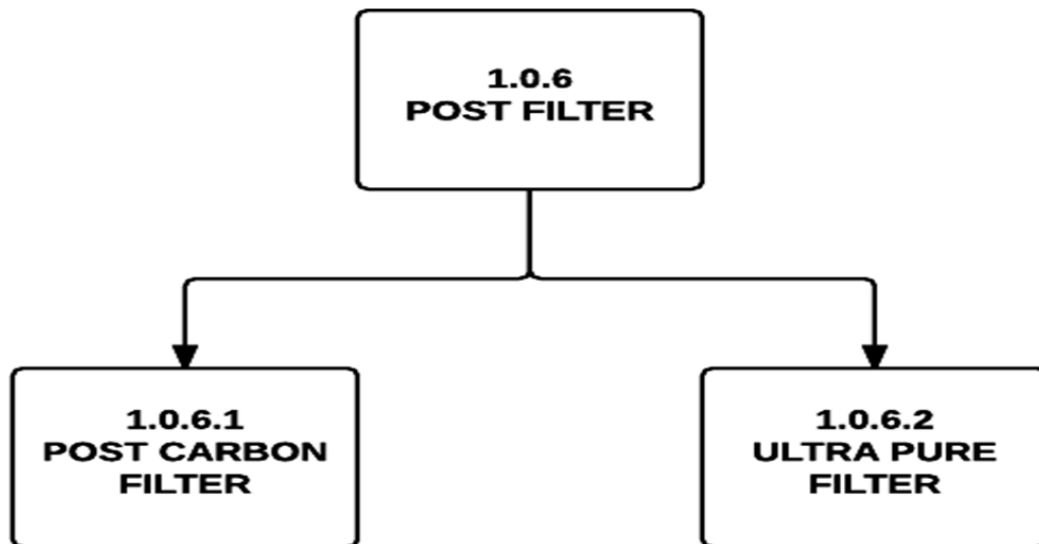

Figure 21. Physical Decomposition Level Two for the Post Filter Subsystem

Tank Subsystem

There are three storage tanks to be incorporated to the water system: Non-potable Water Tank, Rain Water Tank and Potable Water Tank. The physical decomposition of the tanks is shown in Fig 24. Each of the tanks will hold up to 10,000 gallons of water. The rainwater tank is incorporated to maintain the cost effective target of the IBWS and to minimize frequent replacement of the water filters. The rainwater tank is used to catch rainwater during rainy season. Both rain and borehole water are pumped through the water purification system. The rainwater will serve as a substitute to the borehole water and used most of the time during rainy season between the month of April and October each year. The non-potable water tank serves as a temporary storage tank for the borehole water prior to purification. Water is pumped to the tank twice daily. Non-potable water runs through the purification system with the help of force of gravity and water pressure.

The potable water tank is designed to keep water pressurized in tank when it is full. An automatic water shut off valve (SOV) is fitted to close and stop water from entering the membrane. As water is being drained from the potable water tank due to usage, the pressure in the tank will drop. The SOV will then open and allow water through the membrane while the contaminated wastewater is diverted down

the drain. A check valve will prevent the backward flow of treated water from the potable water storage tank to prevent the membranes from being ruptured.

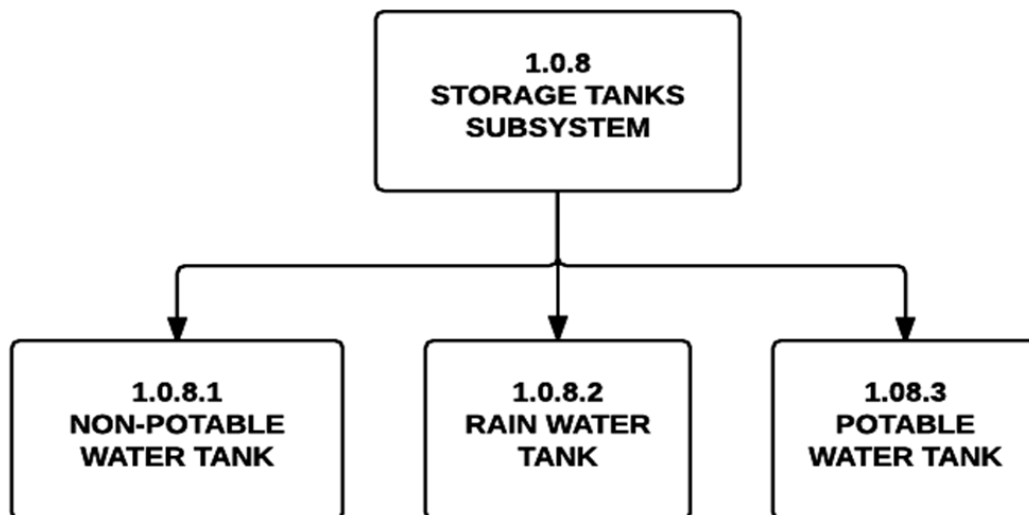

Figure 22. Physical Decomposition Level Two for the Storage Tanks System

Disinfection System

The final stage of the water purification process is disinfection. Ultraviolet disinfection system is a cost effective and environmentally friendly process of removing 99.99% of harmful waterborne microorganisms. It is designed to use a UV light to disinfect the purified water that flowed through the post-filtration subsystem. This system disinfects water without adding or taking minerals away from the water.

4.2 WATER SAMPLING ANALYSIS

An effective water sampling procedure involves ensuring that the installation of the water purification components during maintenance are properly sanitized and flushed. Proper maintenance would help trace water contamination once water does not meet the PH requirements in accordance with WHO's regulations. Figure 26 shows the water sampling logic diagram. One must first monitor the water by taking water samples once it completes the cycle in the disinfection system. The PH indicator will show whether the PH values of the water is within the range of 6.5–8.5. If the water meets the PH requirement, the quality of the water is good for consumption and meets the drinking water requirement.

The purified water that do not meet the drinking water requirement may be adequate to be used in industries or irrigation purposes without being treated. In the event that the drinking water does not meet the PH requirement, it is imperative to identify the source of contamination to ensure that the water system is free from contamination. Upon determination of source of contamination, strict strategies will be implemented to prevent the introduction of contaminants to the water system. Drinking water quality will require further treatment by recycling the water through the water system to repeat the sampling process.

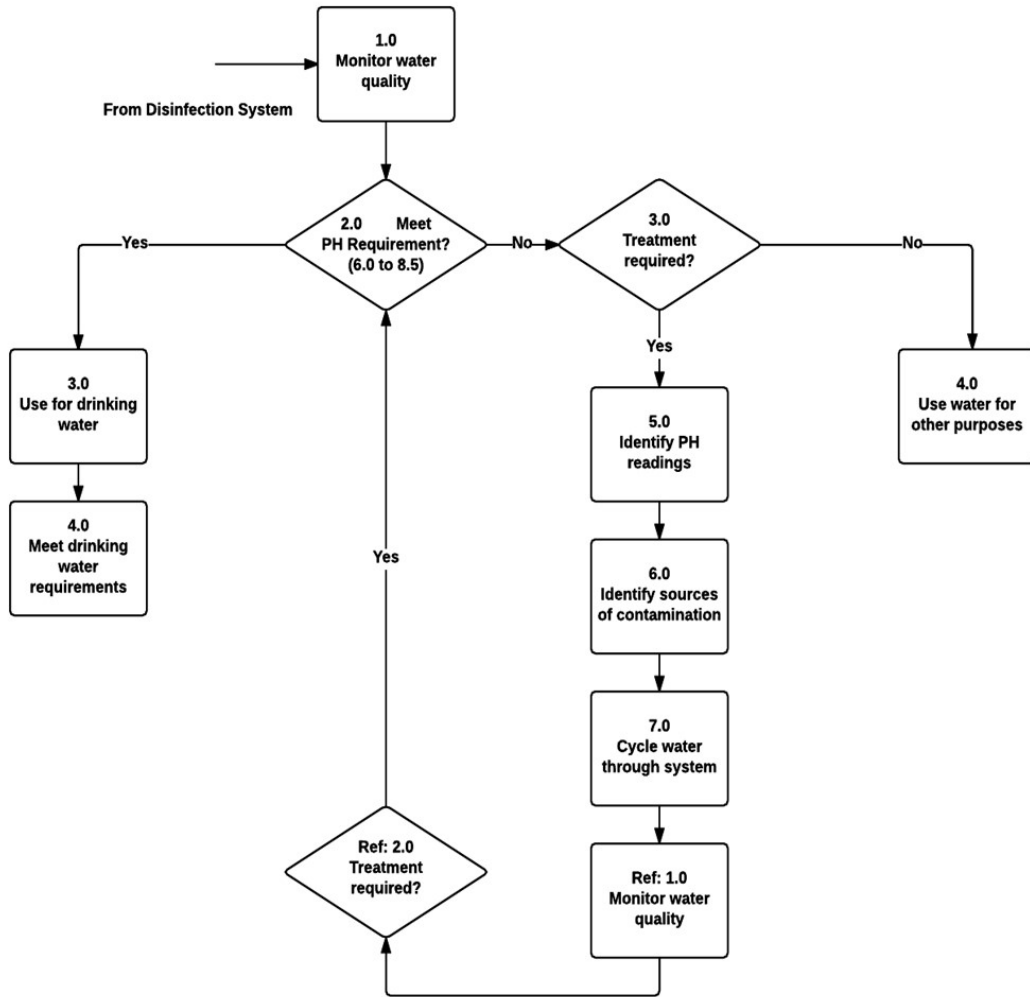

Figure 23. Water Sampling Logic Diagram

4.3 WATER PURIFICATION SYSTEM PHYSICAL MODEL

As the Navy focuses on better cost-effective ways to develop systems that are to fulfill the capability gaps of already existed systems, there is need for an operational prototype to ensure that the proposed design will be feasible. The first component of this process is to build a scale prototype to represent the feasibility of the water purification system design. The main objective of an operational model is to ensure that the features of the system that is being designed is going to influence the proposed design. For the purpose of this thesis, the author used some COTS components and assembled an operational model of the water system, which serves as a foundation for the design of the main model.

Model Development and Implementation

In the operational analysis section of this thesis, an operational concept diagram was introduced to show the proposed concept of the water purification system. This model development was influenced by system operational concept and the block diagram of water purification model in Figure 27. Turning to the discipline of the operations analysis, the model guided the operation of the prototype. The model illustrates the operational sequence during water purification. The water from the non-potable tank or rainwater tank is pumped after being passed through the detection and monitoring system. Water flows through each of the two stages of the pre-filter subsystem. Once the pre-filtration is completed, the water then pushed through each of the membrane filters and finally to the storage tank. From the storage tank, the water makes one more loop through the post-filter assemblies and

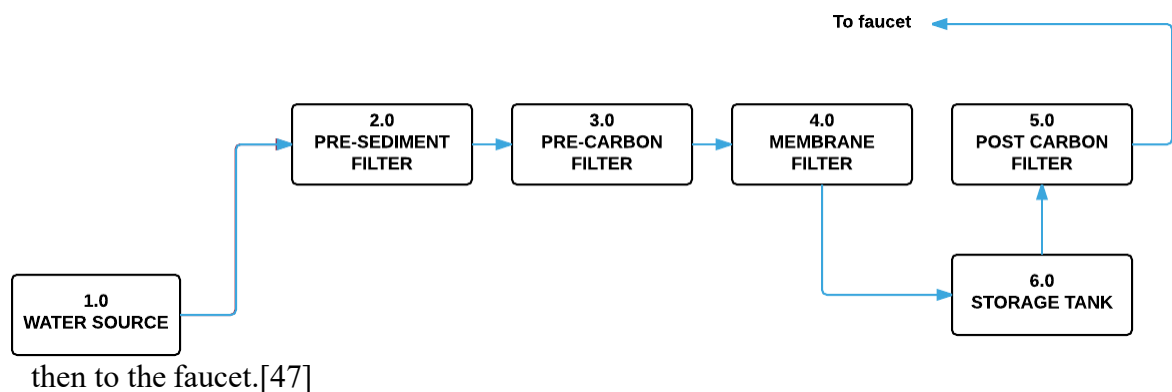

Figure 24. Block Diagram of Water Purification Mode Prototype Model

Using the model in Figure 24 as a reference, the prototype model was assembled using Philip screwdriver, small knife, and Teflon tape. The prototype model is a four stage, point-of-use water purification system with a flow rate of 50 GPD. post-filter. Its dimensions are 17" L x 12" W x 4" D with a 3.2-gallon capacity storage tank. The prototype water purification system parts list is shown in Table 12.



Figure 24 shows the prototype water purification system. The components of the system influence one another in the context of system integration. The results gathered from the test, operation, and evaluation of the prototype will form the basis for development of the water purification system in the areas of design for reliability, maintainability, and supportability.

Figure 25. Four Stage Prototype Model Integration

1. **Operational Test and Evaluation**

The purpose of operational test and evaluation (OT&E) is to “facilitate the necessary validation of the system configuration to provide assurance that it will meet the specified requirement” (Blanchard and Fabrycky 2011, 164). The high-level user requirements of the water purification system are for the system to be able to monitor, filter, purify, disinfect, and store potable water. These high-level user requirements are the capabilities of the water purification system the author intend to validate during the OT&E process. The water system prototype OT&E will follow further steps and processes to ensure that the system configuration meets the high-level operational requirements specified during the conceptual design phase.

For this OT&E of the water purification system, Type 2 testing process was used. Type 2 testing is the “activity associated with the initial qualification of the system for operational use” (Blanchard and Fabrycky 2011, 169). Type 2 testing is adopted because COTS do not require much testing but must be validated to ensure that they are compatible when integrated with other components (Blanchard and Fabrycky 2011). Two individual tests that are tailored to the user need are identified:

Components performance test and personnel test and evaluation. Performance tests will verify individual system performance characteristics of the water purification system such as the production rate, water flow, and performance of system components. Personnel testing and evaluation will verify the interface between the operators and water purification system. Additionally, it will verify skills, training and time required to perform maintenance. Table 13 shows the OT&E validation checklist.[48]

Table 11 OT&E Validation Checklist. Adapted from ESP Water Products (2016).

Task Number	Item	Functions (SV-4)
1	Evaluation of high-level requirements (Monitor, Filter, Purify, and Store water)	2.0, 3.0, 4.0, 5.0
2	Verify technical data accuracy (Flow Rate, Production Rate)	1.0
Task Number	Item	Functions (SV-4)
3	Evaluation of water system component performance (Output)	2.0,3.0,4.0,5.0
4	Verify personnel skill-level with system (Easy to Use, Maintenance Concept)	N/A
5	Verification that user needs are met	N/A

2. Pre-Water Treatment Test Analysis

Prior to activating the water purification system, the author tested the tap water obtained from the sink of his kitchen to determine the water condition. The conditions stipulated by the manufacturers for the operation of the membrane with thin film composite (TFC) are summarized in Table 14.

Table 12. Conditions for Operation of TFC Membrane. Adapted from ESP Water Products (2016).

Source Water Supply-TFC	
Community/Private	Bacteriologically Safe
System Pressure min/Max	30 to 100 psi
Temperature	40 to 100 degrees
PH Range	3.0 to 11.0
Maximum Supply TDS Level	2000 mg/L
Turbidity	<1.0 net turbidity (NTU)
Chemical Parameters-TFC	
Hardness (CaCO ₃)	<350 mg/L (<20 gpg)
Iron (Fe)	<0.1 mg/L
Manganese (Mn)	<0.05 mg/L
Hydrogen Sulfide (H ₂ S)	0.00 mg/L
Production Rate	
Efficiency Rate = 12.1%	Percentage of the available water to the user as the system treats water under operating conditions daily.
Recovery Rate = 21%	Percentage of water to the membrane that is available to the user as the system treats water without a storage tank.
Daily Production Rate = 50 GPD	

The author ensured that the tap water being used was bacteriologically safe prior to running the system by performing a bacteria test. A bacteria vial was set upright on the kitchen counter and carefully filled it with water at 5 ml line. The cap was replaced and tightly covered to prevent leakage. The vial was shaken vigorously for 20 seconds and then placed upright in a cool dry area of a temperature between 70 to 90 degrees for 48 hours (BRK Brands 2005). After 48 hours, the vial was observed to determine its color. For this test, purple color showed negative result indicating that no bacteria were detected in the water. Yellow color would show positive result indicating a chance that harmful bacteria were detected in the water (BRK Brands 2005).

Next, the author performed the lead and pesticide test to determine if there are presence of dissolved lead at levels below the Environmental Protection Agency (EPA) recommended action level of 15 parts per billion (ppb) (BRK Brands 2005). The

Pesticides Test is designed to detect pesticides like atrazine and simazine below the EPA Maximum Contaminant Level of 3 ppb and 4 ppb respectively (BRK Brands 2005). A dropper from the test kit was used to place two dropper-full of water sample into the test vial. The water droplets were shaken for 2 seconds and placed on the kitchen counter. Both test strips for lead and pesticides were placed into the test vial for 10 minutes with their arrows pointing DOWN. After 10 minutes, the test strips were taken out of the vial to read the results. The bottom line (next to the number, 1) appeared darker than the top line (next to the number, 2). The bottom line appearing darker than the top line is a negative test result, which indicates that the water has neither dissolved lead nor pesticides. Positive test would have shown the top line of the test strips (next to the number, 2) darker than the bottom line (next to the number, 1), or both lines being dark indicating presence of dissolved lead and pesticides in the water.

The tests and results are presented in Table 15. The author observed that the tap water total hardness indicated 425 ppm, which is much higher than the <50 ppm drinking water requirement. Furthermore, the PH value was at 8.5 ppm, which is within limit of WHO but high. The total alkalinity of the tap water showed a very high value of 180 ppm more than the accepted value of <120 ppm for drinking water. Other tests such as bacteria, lead, pesticides, total nitrate/nitrite, nitrite, total chlorine, free chlorine, and bromine wert.

OT&E Procedure

Prior to the assembly of the model, the author verified all components to ensure they are the right parts and in proper configuration. All parts of the system prototype model were assembled using simple tools as specified by the manufacturers. For easy identification of the model components, all water tubing was labeled and color coded. Figure 28 shows the assembly and configuration of the prototype model. The feed water valve was connected to the pre-filter using a 1/4" red tubing. The feed water tubing connects from the cold water hose to the pre-filter. A 1/4" black tubing connects the membrane drain port to the sink drain port.

Prior to activating the system, all the supply and drain lines were checked for leak and ensured they are secured. The water flow valve was slowly turned ON while the storage tank valve was turned one quarter turn counterclockwise to open the valve. The water faucet was opened for the product water to flow until all the air was expelled. Once the air was expelled from the system, the product water faucet was closed. The storage tank was allowed to fill up within 4 hours and the water was dispensed to drain twice (ESP Water Product 2016). This process was performed in order to clean the storage tank from the factory installed sanitizing solution.[48]

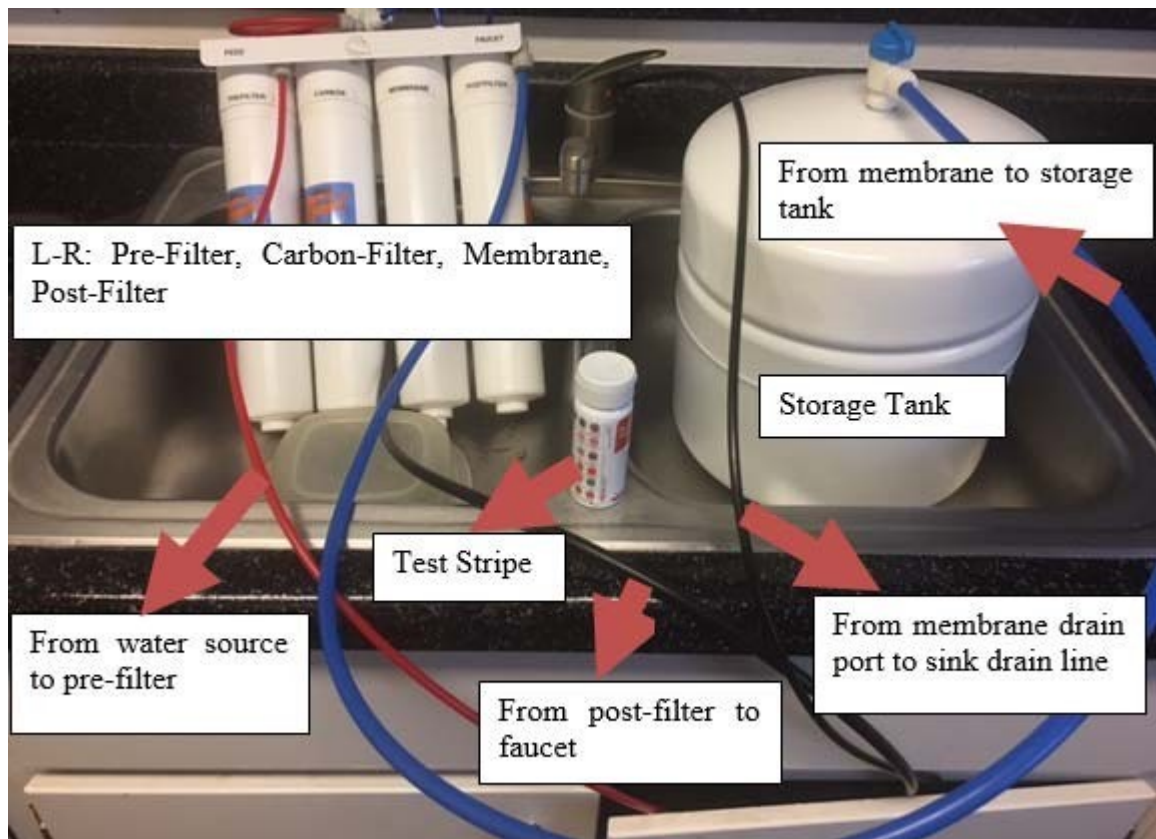

Figure 26. The Water Purification System Prototype Model Configuration

With the completion of the evaluation of the high-level system operational requirements and technical data accuracy, the author performed a post-test of the treated water to determine if there are significant difference in values between the pre-treated water and the treated water. For the purpose of this thesis, the test results that were within limits were repeated to see if there may be any decrease in the values obtained. The water sample tests were repeated as in paragraph three above. The post water-treatment test results are compared to the pre water treatment results, as shown in Table 16.

Test result showed that the tap water total hardness decreased to 30 ppm and below <50 ppm drinking water requirement. Furthermore, the PH value was at 7.0 ppm, which is within the acceptable limit of WHO. The total alkalinity of the tap water showed

The maintenance skill level needed for the water system prototype model is simple hands-on maintenance. Removal and replacement of the filter elements is easily performed by hand and requires about five minutes to complete. Additionally, routing of the color-coded tubing took about three minutes to complete. It is not expected that the actual water purification system maintenance is the same as the prototype model; however, the author expects that maintenance requirement of the actual system should not take more than one hour. From this evaluation of the personnel skill-level with the prototype model, the author concludes that it is adequate.

Finally, the objective of the prototype model was met. The test and evaluation of the prototype provided good feedback on how well the system will perform in its operating environment and to identify any problem that was detected. The system performance was adequate and there were no corrective action or modifications required. The prototype model for OT&E to this point proved that the system is expected to meet user needs as specified.[49]

4.4 SYSTEM RELIABILITY ANALYSIS

The water purification system will use backup components to create redundancy and improve the reliability of critical functions. Reliability is the measure of the “ability of a product or part to perform its intended function under a prescribed set of conditions” (Kumar et al. 2006). In order to analyze the reliability of the water system, basic reliability terms are defined in Table 17. In system engineering process, reliability prediction is very important in the “Design for Reliability process during the system development stage” (Crowe and Feinberg 2001). Predicting the reliability of any system will “provide an early estimate of the design complexity that relates to the product reliability” (Crowe and Feinberg 2001). (2006).

System Overall Reliability Model

The high-level objective of this thesis is to show that the Improved Borehole Water System is affordable, easy to maintain, and easy to operate without the need for a continuous electrical power; the complete reliability model of the water system is shown in Figure 30. Figure 30 shows a set of two pre-sediment filters and pre-carbon filter are in parallel configuration with another back-up set of pre-filter sediment filter and pre-carbon filter respectively. A switch is added between the monitor/detector system and each set of pre-sediment and pre-carbon filters. The switch will

automatically transfer the operation of one set of pre-sediment and pre-carbon filters to the similar backup pre-sediment and pre-carbon filters in the event of failure as shown in Figure 30.

The water purification system has six membrane filters that are connected in a parallel network as shown in Figure 30. The membrane filter element will continue to operate regardless of damage to any of the membranes. As in pre-filters, a set of post-carbon and post-ultrapure filters are in parallel configuration with another set of back-up post-carbon and post-ultrapure. A switch was installed between the storage tank and the set of post-carbon and post-ultrapure filters to automatically transfer the system operation to the backup components in the event of failure. The backup unit will not operate until the failure sensor recognizes of a failure in the operating set of components and automatically switches operation to the standby unit.

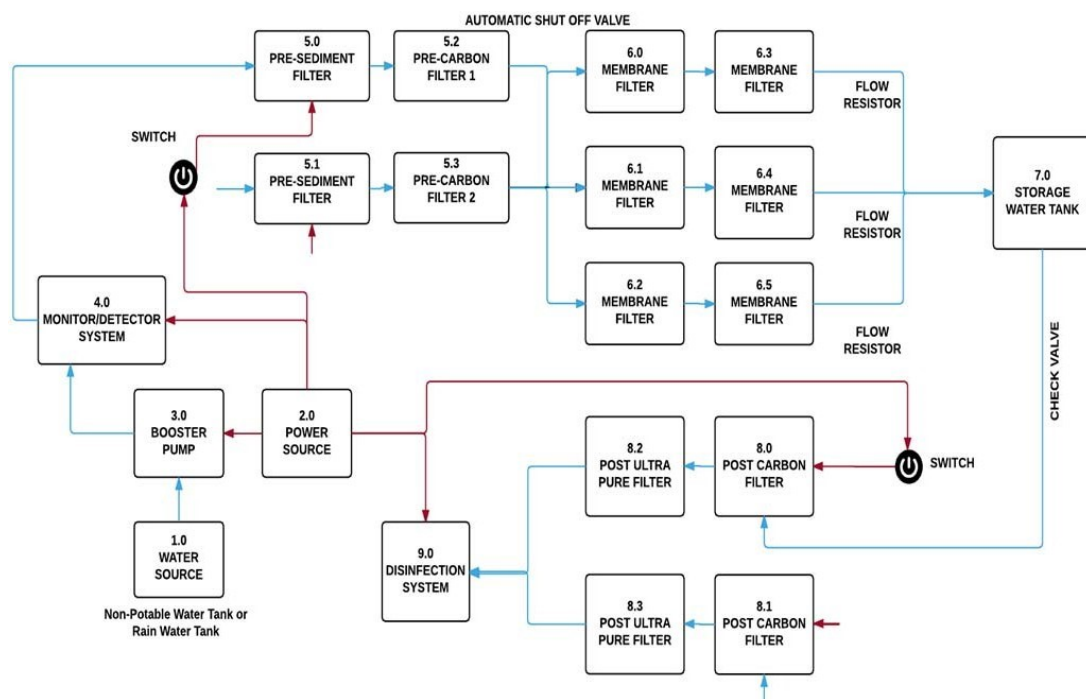

Figure 27. Water System Reliability Model

The author worked as the Auxiliaries Mechanical and Assistant Chief Engineer Officer aboard an FFG-7 Class frigate. With his experience of the past design of water purification products that were used aboard the FFG-7 Class frigate, it is the author's belief that the design of the system components of the MROS is very similar to the design that was used aboard the vessel. Therefore, it is assumed that the reliability of the filter elements and their housing would be similar to the other products. According to the component manufacturers, each of the pre-sediment, carbon, and ultrapure filters are expected to be replaced after every year at 8,640 hours (AXEON 2013). This operating hours of the filters is obtained based on the annual replacement frequency of the filters. Similarly, each of the membrane filters is expected to be replaced

biennially at 17,280 hours. The operating hours is based on the manufacturer's recommended biennial replacement of the membrane filter elements (AXEON 2013).

With the incorporated redundancy to the system design, the overall reliability of the water system can be estimated. It is predicted that standby redundancy will have higher reliability than the operating redundancy. Figure 31 illustrates a series network reliability block diagram (RBD) for the non-potable water tank, rainwater tank, power system, pump system, and monitor systems. The systems are in series and must operate in a satisfactory manner for the water system to function properly. The systems reliability is the product of the reliability for the individual system expressed as:

$$R = (R_{NPMtank}) (R_{RMtank}) (R_{POMER}) (R_{PUNP}) (R_{M/D}) \quad (3) R = (0.99) (0.99) (0.99) (0.99) (0.99) = 0.9513$$

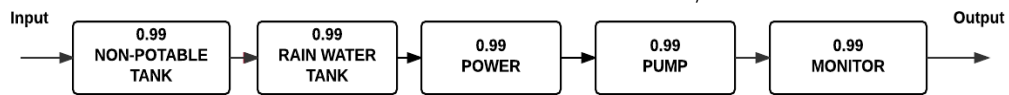

Figure 28. RBD of Non-potable tank, Rain water tank, Power, Pump, and Monitor Systems

Next is the set of pre-sediment and pre-carbon filters. Each set is in series and have a parallel standby connection as shown in Figure 32. The reliability of the set of the pre-filter subsystems in operation is calculated as shown.

$$R = (R_{PS}) (R_{PC})$$

4)

$$R = (0.98) (0.98) = 0.9604$$

To determine the reliability of the standby system, the standby system follows the Poisson distribution “because standby systems display the constant λt characteristics of this distribution” (Blanchard and Fabrycky 2011, 397). As shown in Figure 32, there is one set of operating subsystem and one set of identical standby. It is assumed that the reliability of the switch is 100%. Recall that each of the pre-filters are expected to operate over $t = 8,640$ hours with a failure rate (h) of 0.0001 failure/hour (1/MTBF).

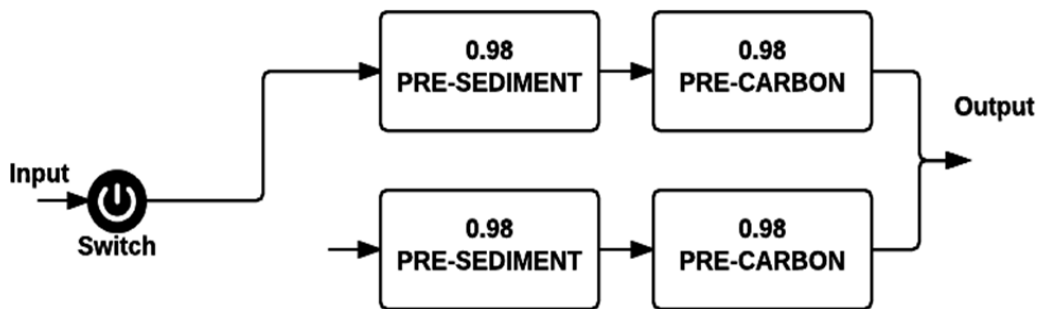

Figure 29. RBD of the Pre-filters

The reliability of the set of standby subsystem (pre-sediment and pre-carbon filters) is estimated as shown. The probability of no failure is represented by the first term, e^{-ht} ; the probability of the one failure is $(ht)e^{-ht}$ and so on. In the configuration of Figure 32, it is expected that one failure will occur with one subsystem in fully operational condition.

$$P(\text{One set Standby system}) = e^{-ht} + (ht)e^{-ht} \quad (5) R = e^{-(0.001 \times 1000)} + (0.001 \times 1000)e^{-(0.001 \times 1000)}$$

$$= 0.4214 + 0.3641 = 0.7856$$

The calculation shows that the standby system of the pre-sediment and pre-carbon filters have reliability of 0.7856. With this value, both the operational system and the standby system overall reliability of the pre-filters as shown.

$$R = 1 - (1 - R_{PSPC})(1 - R_{ST\&ENDBF}) \quad (6)$$

$$R = 1 - (1 - 0.9604)(1 - 0.7856) = 0.9912$$

The earlier prediction that the standby system has higher reliability than operating redundancy can be validated. Assuming that the design was for the operating redundancy and the subsystems are operating throughout the purification period. The reliability of the configuration is determined as shown.

$$R = 1 - (1 - R)^2 \quad (7)$$

$$R = 1 - (1 - 0.4214)^2 = 0.6652$$

As predicted, the reliability of the standby system is higher (0.9912) than the reliability of the system using operating redundancy (0.6652).

The six identical membrane elements are in parallel. All the membranes must fail to cause total system failure. The parallel network of the membrane elements is shown in Figure 33. The component reliability is calculated as shown. The reliability of the storage tank is assumed to be 0.99.

$$R = 1 - (1 - R_1)(1 - R_2)(1 - R_3)(1 - R_4)(1 - R_5)(1 - R_6) \quad (8)$$

$$R = 1 - (1 - 0.99)(1 - 0.99)(1 - 0.99)(1 - 0.99)(1 - 0.99)(1 - 0.99)$$

$$= 1.00$$

The overall reliability of the membrane elements is approximately 1.00.

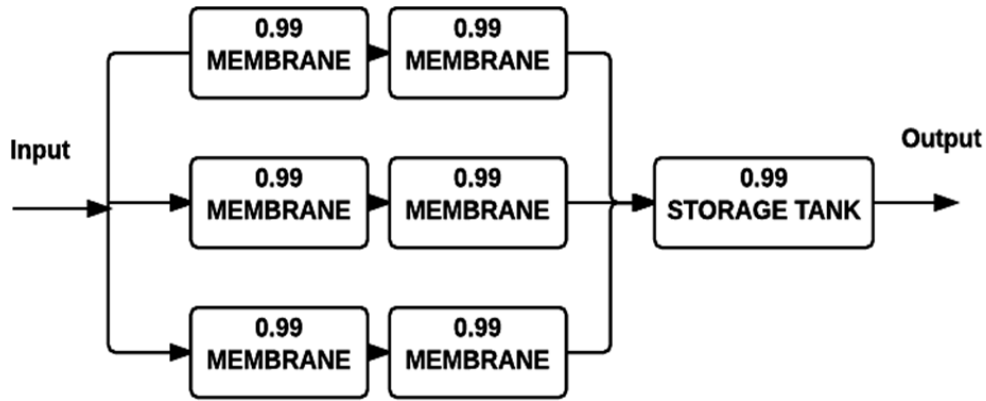

Figure 30. RBD of Membrane Elements

For the post-filters reliability, the same calculation that was made for the reliability of the pre-filters are repeated for the post-filters and the same results were obtained since they have similar failure rate and MBTF. As shown in Figure 34, there is one set of operating subsystem and one set of identical standby. It is assumed that the reliability of the switch is 100%. Recall that each of the pre-filters are expected to operate over $t = 8,640$ hours with a failure rate (λ) of 0.0001 failure/hour (1/MTBF).

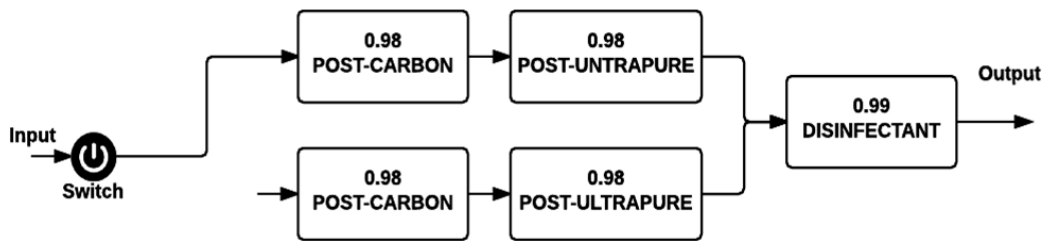

Figure 31. RBD of the Post-Filters

The standby system follows the Poisson distribution “because standby systems display the constant λt characteristics of this distribution” (Blanchard and Fabrycky 2011, 397). The reliability of the set of standby subsystem (pre-sediment and pre-carbon filters) is calculated as shown. The probability of no failure is represented by the first term,

e^{-ht} ; the probability of the one failure is $(ht)e^{-ht}$ and so on. In the configuration of Figure 34, it is expected that one failure will occur with one subsystem in fully operational condition.

$$P(\text{One set Standby system}) = e^{-ht} + (ht)e^{-ht} \\ = 0.4214 + 0.3641 = 0.7856$$

$$(9) R = e^{-(0.0001 \times 8640)}$$

The calculation shows that the standby system of the pre-sediment and pre-carbon filters have reliability of 0.7856. With this value, both the operational system and the standby system overall reliability of the pre-filter as shown.

$$R = 1 - (1 - R_{PSPC})(1 - R_{ST\&ENDBF}) \quad (1)$$

$$R = 1 - (1 - 0.9604)(1 - 0.7856) = 0.9912$$

Therefore, the overall reliability of the water system was estimated as shown.

$$R_{Mater\ SYCTEN} = (R_{NPT,RMT,PMR,P,M})(R_{Pre-fiSter})(R_{MENbrane})(R_{Tank})(R_{Poct-fiSter})(R_{Dicinfectant}) \quad (11)$$

$$R_{Mater\ SYCTEN} = (0.9509)(0.9912)(0.9900)(0.9900)(0.9912)(0.9900) \\ = 0.9064$$

From the reliability analysis, the estimates show that the water purification system

Fault-Tree Analysis

Fault-tree analysis focuses on different ways in which a specific water purification system failure can occur, and the probability of its occurrence is presented. The water system fault tree helps to identify the undesired outcome or event that may occur while the system is in operation and then determines what event or combination of events could cause the desired event (Ball 2003).

Figure 34 illustrates the fault tree analysis of the water system. The top level event failure is the loss of water production and its causal hierarchy in the form of a fault tree is shown. The loss of water production occurs when the water system cannot pump water, water tank is empty, and loss of water pressure in the membrane. As indicated in the diagram, the system will lack pump capability when the pump is damaged, no power availability, or no feed water in the water pump. The inoperability of the pump refers to the failure of one or more internal parts in the pump system. Similarly, the pump does not turn ON without feed water running through it. Additionally, the pump is operated by electricity and will not turn ON without electrical power.

Lack of water pressure in the membrane will result in slow or interruption of the water production process. Pressure drop in the water system may be due to change in pressure in clogged filters. Filters may clog when the pre-filters are not working in accordance with specification. Filters may also clog when adequate filter maintenance was not performed at the due dates. Dirty filters will prompt the change in differential pressure (Delta-P) to pop. Delta-P is a red button mechanism in the water filter, designed to pop-out when the filters need replacement or certain maintenance. The popping of Delta-P push button indicates that the filters need replacement.

The best way to improve the reliability of the water system to ensure that water production is not interrupted is to have a spare water pump. The spare pump will be used immediately the pump in operation is not available. There are two redundancies for power supply. The emergency generator or the city electric supply will be used when the solar power is unavailable. Furthermore, the membranes will be inspected daily during scheduled down time maintenance to ensure that Delta-P push buttons do not indicate that the filters require replacement. Clogged filters will be replaced with new filters to avoid interruptions of water production.[49]

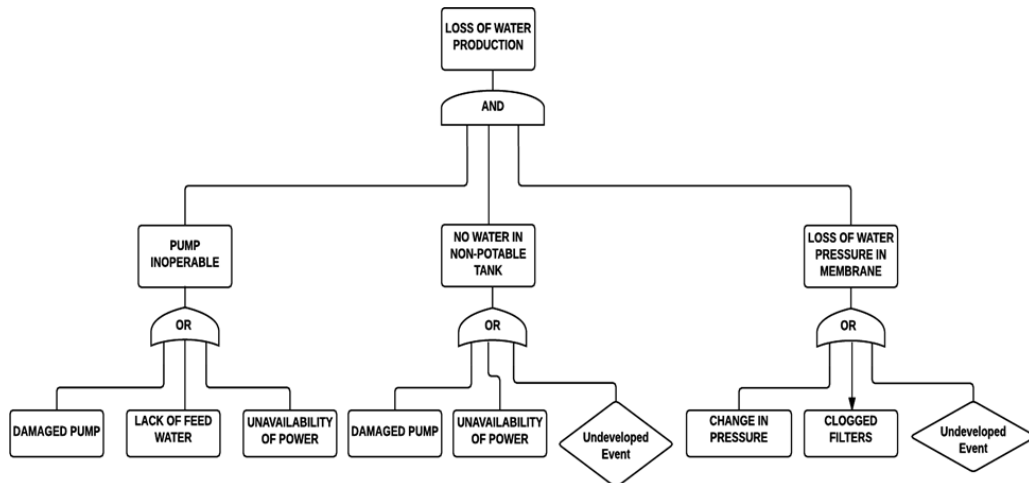

Figure 32. Fault Tree Analysis of the Water System

4.5 INTEROPERABILITY REQUIREMENTS

Interoperability of the water system was defined during the conceptual phase of the system design. The water system is designed to be able to interface and work with the external systems to achieve the objective of the purification process. Interoperability of the water system includes systems, subsystems, process, procedures, organizations, and objectives over the life cycle. As shown in the interoperability diagram of Figure 36, each external system and water system subsystems interface with one another in order to enhance the purification process. Each component has a part to play during the water purification cycle.

From a systems engineering perspective, interoperability of the water system was evaluated during the requirement development, design verification, and T & E verification. Each of the evaluation of the water system showed that the system is able to operate successfully with the interface of other external systems. In the life cycle management perspective, continuous on-job training of the technicians and the maintenance processes of the water system shows interface of the system and the maintainers.

Spare parts are ordered through the military stock system by interfacing with the dealers or manufacturers supply system. The system's user and the parts dealers will continue to correspond on the status of the ordered parts until it arrives.

CHAPTER-5

5.1 OPERATIONAL USE AND SYSTEM SUPPORT

The system “maintenance concept provides the foundation that enables the design and development of the maintenance and support infrastructure and defines the specific design-to requirements for the various elements of support such as test and equipment, facilities, transportation, and handling equipment” (Blanchard and Fabrycky 2011, 95). The maintenance concept of the MROS shall include maintenance levels, maintenance support locations, frequency of maintenance, and environmental requirements. Supply support is critically important in the life cycle of every system, equipment and components.

The maintenance and support concept of the MROS was incorporate at both the conceptual and detail design phases of the system to ensure that parts are readily available for maintenance. The operating log of the water system must be maintained and copies sent to the local parts support upon request in order to validate the manufacturer’s warranty (AXEON 2013). The maintenance and support concept was developed in the user need analysis section of the thesis, which evolved from the water systems operational requirements definition. maintenance and custody of the system. The system manufacturers are to perform the depot level maintenance such as overhaul, supply support, detail maintenance, and rebuild of some specific components. Local parts supply facility.

According to the manufacturer’s guidelines, the sediment and carbon filters are to be replaced every 12 months while the membrane filters will be replaced every 24 months. Unscheduled repairs are to be conducted in accordance with the maintenance instructional manual provided by the system manufacturers. Pre-expended bins for consumable parts will be available for the users to store on hand spare parts. Components spare parts will be constantly supplied by the local supply support facility throughout the life cycle of the water system. As stated in the operational requirement section, the system will not be affected by the environment where it is to be operated. Although the system will not be efficient in water production at low temperatures, this concern will not be a problem in West Africa as the temperature do not drop below 60 degrees. Environmental shocks and vibration will not affect the system because earthquakes are not common in its operational environment.

CHAPTER-6

CONCLUSION

The main objective of this research was achieved. The objective to incorporate a purification system to the BWS design to improve its capability for the local population as well as U.S. forces that will operate in West Africa was met. This thesis showed as a proof of concept of the feasibility of adding a purification system to the borehole water system. The research concludes that MROS would provide quality water usable to the local population and U.S. forces that will operate in West Africa in the future.[50]

From Chapter I, recall the research questions that were posed:

- (1) What modifications need to be made to the existing West African borehole water system (BWS) to make potable water?
- (2) What water purification system can be incorporated with BWS to provide cost-effective and safe water to U.S. forces operating in West Africa?
- (3) Would the water purification system be operationally feasible, technically feasible, and cost-effective for U.S. forces operating in West Africa?

To answer research question 1, Chapter I of the thesis discussed and established the user needs during the conceptual design and analysis phase of the water purification system. From the author's experience of having lived and grew up in Nigeria, West Africa, he discovered that the current borehole water system needs a purification system. The study on the quality of the borehole water in West Africa showed that dependency on the naturally filtered ground water is not sufficient for human consumption. The presence of metal compound and bacteria in the borehole water indicate a need for purification system.

LIST OF REFERENCES

- [01] Adelekan, B.A. 2010. “Water Quality of Domestic Wells in Typical African Communities: Case Studies from Nigeria.” *International Journal of Water Resources and Environmental Engineering*2(6) Vol. 281: pp.137–147.
- [02] Akudago, John, Larry Chegbeleh, Makoto Nishigaki, Nukunu Nanedo, Anthony Ewusi, Kwabena, Kankam-Yeboah. 2009. “Borehole Drying: A Review of the Situation in the Hydrogeological System in Ghana.” *Journal of Water Resource and Protection*. Vol. pp. 153–163.
- [03] Balogun, Isaac, Adebayo Olatunbosun, Sojobiand Bosede, and Oyegbemijo Oyedepo. 2020. “Assessment of Rainfall Variability, Rainwater Harvesting Potential and Storage Requirements in Odeda Local Government Area of Ogun State in Southwestern Nigeria.” “*Journal of Cogent Environmental Science.*”1: Vol. 386, 2008.pp. 1–37. DOI:
- [04] Blanchard, Benjamin, and Wolter Fabrycky. 2011. *Systems Engineering and Analysis*. Upper Saddle River, NJ: Pearson. Vol. 386, No. 1, pp. 155–163, 2008
- [05] Boensel, Matthew. 2020. *Engineering Economies and Cost Estimating SE 3011 Lecture Slides*, Naval Postgraduate School. Monterey, CA.Throughout the System Engineering Process. Accessed May 6, 2020. Vol. 145, pp. 139–154, 2015.
- [06] CraftRO Master 10,000 GPD Brewery Water System. 2016. Accessed November 10, 2016. Vol. 106, pp. 356– 366, 2017
- [07] Department of the Army, Medical Technical Bulletin (TB MED 577). 2010. “Sanitary Control and Surveillance of Field Water Supplies.” Accessed May 5, 2020. Vol. 4, pp. 234-237, 2011.
- [08] Department of the Navy, Marine Corps Reference Publication (MCRP) 3–02C, “Marine Combat Water Survival.” Accessed May 5, 2020
- [09] Emmanuel, Toyobo, and Muili Bamidele. 2013. “Sustainability of Borehole Water Schemes through Community Participation in Ejigbo, Osun State.” *Journal of Innovative Systems Design and Engineering*. 4(9): Vol 119. pp. 79–84.
- [10] ESP Water Products and Benefits. 2020. Accessed September 10, 2020. Vol. 72, pp.713, 1993.

- [11] ESP Water Products. 2016. Understanding Reverse Osmosis (RO): How RO Systems Work and What they do. Accessed Vol. 161, pp. 425–436, 2016. May 8, 2020
- [13] Ezeabasili, A.C., O.I. Anike, and A.U. Okonkwo. 2014. “Management of Urban for Domestic and Industrial Uses and Sustainability in Anambra State, Nigeria.” *International Journal of Water Resources and Environmental Engineering*. 6(8): pp. Vol. 39, pp. 748–764, 2014.
- [14] FLEXEON Systems Benefit and Highlights. 2014. Accessed Vol. 77, pp. 482, May 5 2020.
- [15] Food and Agricultural Organization of the United Nations (FAO). 1999. *Fishery Harbor Manual on the Prevention of Pollution-Bay of Bengal Program*. Accessed Vol. 109, No. 39, pp. 15679–15685, May 5, 2020.
- [16] Fubara-Manuel, Isoteim., and Raphael Jumbo. 2014. “The Effect of Septic Tank Locations on Borehole Water Quality in Port Harcourt, Nigeria.” *International Journal of Engineering and Technology*. 4(5) Vol. 115, No: pp.236–244.
- [17] Gilli, Eric, Christian Mangan, and Jacques Mundry. 2012. *Hydrogeology: Objectives, Methods, Applications*. Boca Raton, FL: CRC Press. Vol. 115, No.